

Maretron NMEA 2000® Network Installation Guide

Installing an NMEA 2000® Network

Installing an NMEA 2000® network consists of interconnecting NMEA 2000® electronic devices using plug-and-play cables and connectors. The following pages provide a brief description of how to set up a NMEA 2000® network using five basic steps:

1. Cable and Connector Network Basics
2. Installing Terminators
3. Supplying Power
4. Grounding the Network
5. Checking the Network

Please note that this installation guide contains a brief description of the basic concepts of installing an NMEA 2000® network and Maretron suggests that you consult a trained professional for any installation. You can learn more about installing NMEA 2000® networks by contacting the National Marine Electronics Association (NMEA) at www.nmea.org and consulting the following documents:

- NMEA 2000® Standard for Serial-Data Networking of Marine Electronic Devices
- NMEA Installation Standards

1. Cable and Connector Network Basics

1.1 Network Topology

The NMEA 2000® cable system uses a trunk (sometimes referred to as the backbone) and drop line topology as shown in Figure 1.

The NMEA 2000® cable system includes five wires within a single waterproof cable: two signal wires, power and ground wires, and a drain wire. The drain wire shields the signal, power, and ground wires from external Radio Frequency Interference (RFI) and helps reduce RFI emission from the cable.

You can connect devices using one of three cable options:

Mini - This is commonly used for the trunk line on the network because of its greater current carrying capacity (8 amps) as

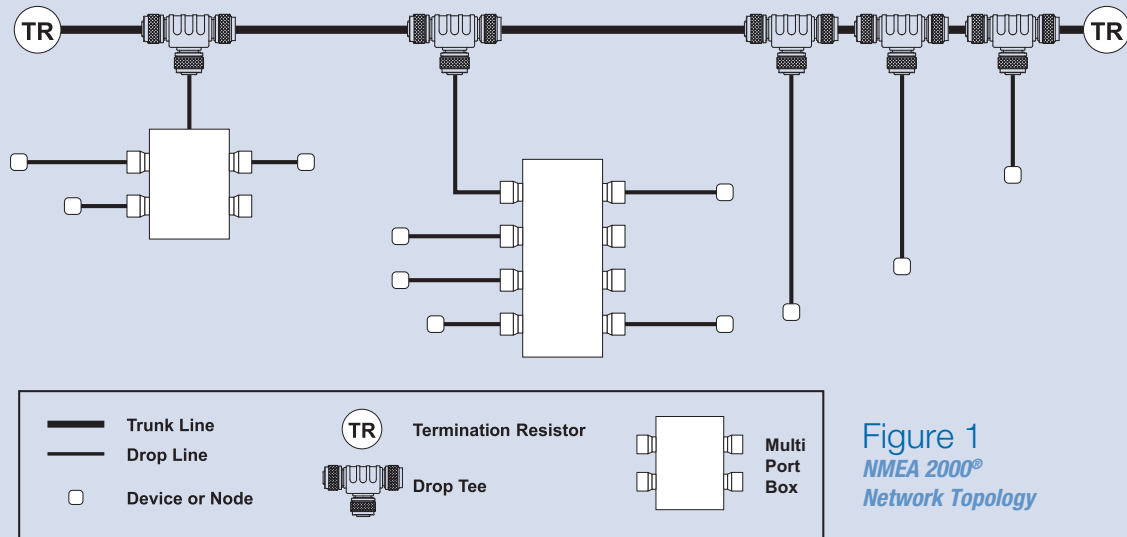

Figure 1
NMEA 2000®
Network Topology

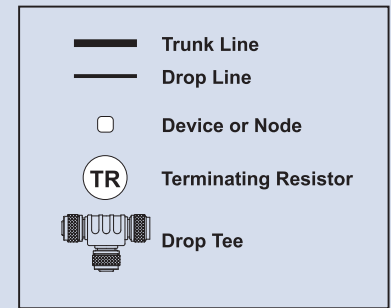
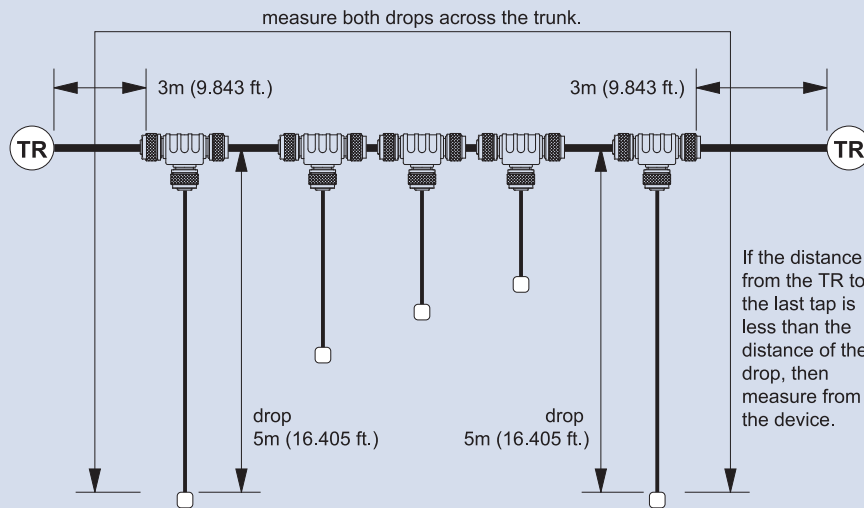

Figure 2
Maximum Cable Length Determination

opposed to Micro cable (4 amps). Mini cable has an outside diameter in the range from 0.41 to 0.49 inches. Its maximum installed bend radius is 7x the cable diameter. You can also use this type of cable for drop lines.

Mid - This is commonly used for smaller networks as either the network trunk line or as drop lines. Mid cable and connectors are rated to 4 amps just like the Micro cable, however the larger diameter power conductors within the Mid cable provides for less voltage drop over Micro cable, especially for long runs. The diameter of the Mid cable is 0.33 inches.

Micro - This cable type is typically used as the drop line connecting devices to the main trunk line with an outside diameter in the range from 0.24 to 0.28 inches. Micro cable has a smaller diameter and is more flexible than mini cable with an installation bend radius of 7x the cable diameter. Smaller networks use this type of cable for both the trunk and drop lines.

You construct the trunk line using double-ended cordsets connected between tees or taps. One end of the cordset has a male connector with male pins while the other end of the cordset has a female connector and female receptacles. The connectors are keyed so they can only connect to each other in one way. As an alternative to double-ended

cordsets, you can make your own trunk line using bulk cable and field-attachable connectors. If you decide to add equipment later, you can simply disconnect a cordset from a tee, add another tee directly to the existing tee, re-connect the cordset and add the new component to the system using a drop cable. Alternatively, you could cut the trunk line, add two field-attachable connectors and insert a new tee. Trunk lines can also be run up to watertight bulkheads and connected to a waterproof bulkhead feed-thru connector to maintain the integrity of watertight compartments.

To drop off the trunk line, you connect a device using a tee connector. Daisy-chaining of devices is not allowed, as it is a requirement to be able to remove a component from the network without affecting any other device. This allows you to remove a device for servicing while the rest of the network remains operational. Multiport boxes are also available where instruments tend to be clustered, around the helm for example.

1.2 Maximum Cable Distance

The cable distance between any two points (a point being an electronic product or terminator) must not exceed 250 meters (820 feet) for a system based on the Mini or Mid trunk cable or 100 meters (328 feet) for a system based on a Micro trunk cable.

For most cases, the maximum distance should be measured between termination resistors. However, if the distance from a trunk line tee to the farthest device connected to the trunk line is greater than the distance from the tee to the nearest terminating resistor (TR), then you MUST include the drop line length as part of the cable length in your maximum cable distance calculation. Figure 2 shows an example where both 5 meter drops must be included in the maximum cable distance since the drops are longer than the distance from the tee to termination resistor.

1.3 Cumulative Drop Line Length

The cumulative drop line length refers to the sum of all drop lines, Mini, Mid or Micro cable in the cabling system. This sum cannot exceed 78 meters (256 feet). Figure 3 shows an example using four drop tees and two multiport drops to attach 11 devices to the trunk line. The cumulative drop line length is 37 meters (122 feet) and no single device is more than 6 meters (20 feet) from the trunk line.

1.4 Maximum Drop Line Length

The maximum cable distance from any device on a branching

drop line to the trunk line is 6 meters (20 feet).

1.5 Maximum Number of Devices

A maximum of 50 physical devices shall be connected to the network, and the disconnection of any device shall not interrupt any other device on the network.

1.6 NMEA 2000® Cable

The Mini, Mid and Micro cables contain five wires: One twisted pair (red and black) for 12VDC power, one twisted pair (blue and white) for signal and a drain wire (bare).

The following table shows the color, name, and usage for each wire contained within the cable.

Color	Name	Usage
White	NET-H	Signal
Blue	NET-L	Signal
Bare	SHIELD	Drain
Black	NET-C	Ground
Red	NET-S	Power

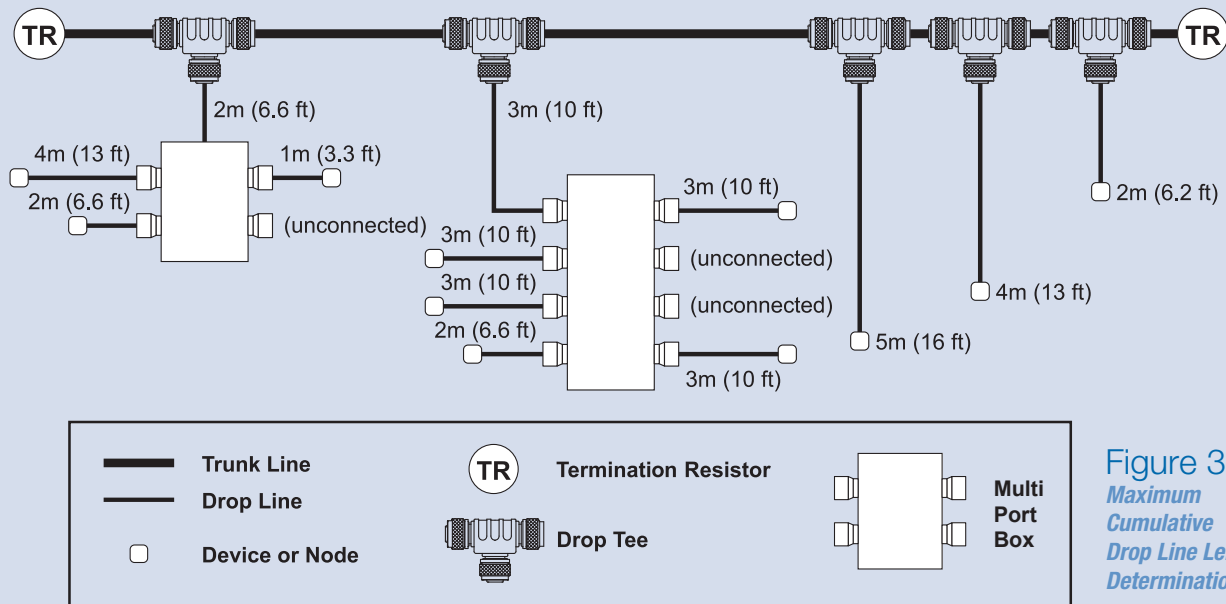

Figure 3
Maximum
Cumulative
Drop Line Length
Determination

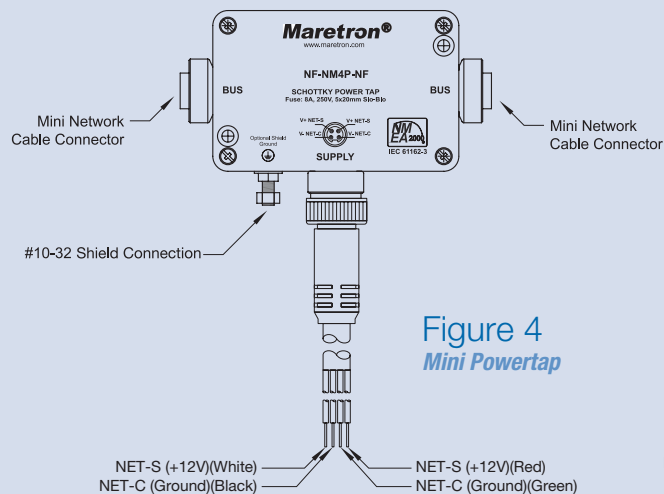

Figure 4
Mini Powertap

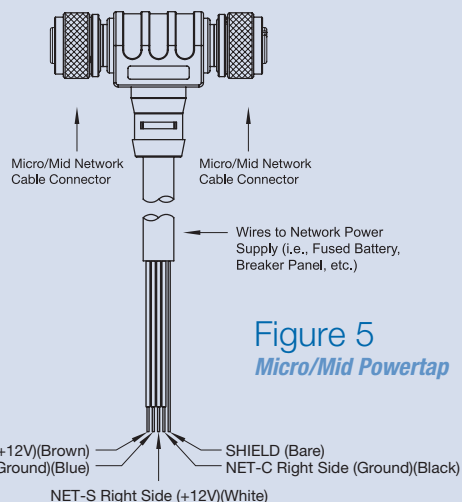
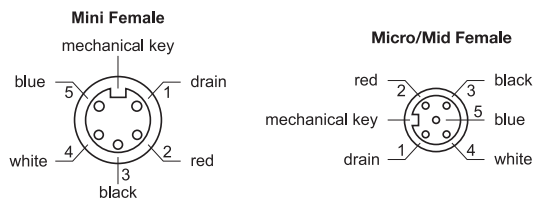

Figure 5
Micro/Mid Powertap

1.7 NMEA 2000® Connectors

Connectors attach cables to devices or other components of the NMEA 2000® cable system. This allows the network to be completely “plug-and-play”. Connections can be made with pre-molded cordsets or with field-attachable connectors. The following diagram shows the pins found within Mini connector and the Micro and Mid connector and the corresponding wire colors for those pins.



2. Installing Terminators

Termination resistors are attached to each end of the trunk cable to reduce reflections of the communication signals on the network. If you do not use termination resistors as described, the network will not operate properly. Termination resistors are typically connected directly to the last tee on the trunk line although they can be connected to a cordset extending from the last tee on a trunk line. Inline terminators are also available and they are used to terminate the network at the last product.

3. Supplying Power

NMEA 2000® networks can use a power supply originating from a single-point connection to the vessel’s 12 volt battery or one or more isolated power supplies distributed along the network, but not a combination of battery and power supply connections. For the purpose of this installation guide, we will focus on the power source being a single-point connection to the vessel’s battery. Over current protection should be provided and should be sized in accordance with ABYC E-11, AC and DC ELECTRICAL SYSTEMS ON BOATS, taking into consideration the smallest gauge of cable being used for the backbone or drop cables. The NET-S wire is connected to the positive side of the battery while NET-C is connected to the negative side of the battery.

3.1 Mini Power Connection

Power is supplied to a Mini trunk line via a Powertap that is shown in Figure 4. Note that the Mini power cable does not have a shield wire as this connection is made to the screw terminal on the Powertap itself.

3.2 Mini Power Capability

Although Mini cable is rated to 8 amps, the cable system can support a total load of more than 8 amps. For example, 16 amps of power could be supplied to the middle of the trunk where 8 amps is supplied to both sides of the power tap. The

Powertap can handle large loads as long as no more than 8 amps is drawn through any single segment of the trunk line. However, cable resistance may limit your application to less than 8 amps.

3.3 Micro/Mid Power Connection

Like the Mini power connection, power is supplied to a Micro/Mid trunk line via a Powertap, which is shown in Figure 5.

3.4 Micro/Mid Power Capability

Micro/Mid cable is rated to 4 amps but like Mini cable, strategic placement of the power source could support higher current. For example, 8 amps of power could be supplied to the middle of the trunk where 4 amps is supplied to both sides of the power tap. It can handle large loads as long as no more than 4 amps is drawn through any single segment of the trunk line. However, cable resistance may limit your application to less than 4 amps

3.5 End-Powered Network

End-powered networks are typically seen on smaller vessels with only a few NMEA 2000® devices. Figure 6 shows an end-powered network.

3.6 Middle-Powered Network

A middle-powered network is typically found on larger vessels and is any network where the power is connected to the network at some location other than at the end. This

network consists of two legs, one leg extending in each direction from the power insertion point. Figure 7 shows a middle-powered network.

3.7 Maximum Power Supply Voltage Drop

The NMEA 2000® network is designed to work properly as long as there is no more than a 1.5 volt difference in the power supply voltage between any two devices on the network. Therefore, you should perform an estimate of the voltage drop across a network using the following equation:

$$\text{Voltage Drop} = 0.1 \times \text{Network Loads} \times \text{Network Length} \times \text{Cable Resistance}/100$$

Where: Network Loads is sum of Load Equivalent Numbers (LEN) for all devices (see device nameplate)
 Network Length is in meters
 Cable resistance is in ohms/100 meters

Power supply voltage drop estimates resulting in less than 1.5 volts across the entire network require no further analysis. Likewise, estimates ranging between 1.5 and 3.0 volts require no further analysis as long as a mid-powered network is used. Occasionally, estimated power supply voltage drops will occur outside these limits and will require further consideration through detailed calculations by certified technicians.

4. Ground the Network

The NMEA 2000® network should be grounded at ONE

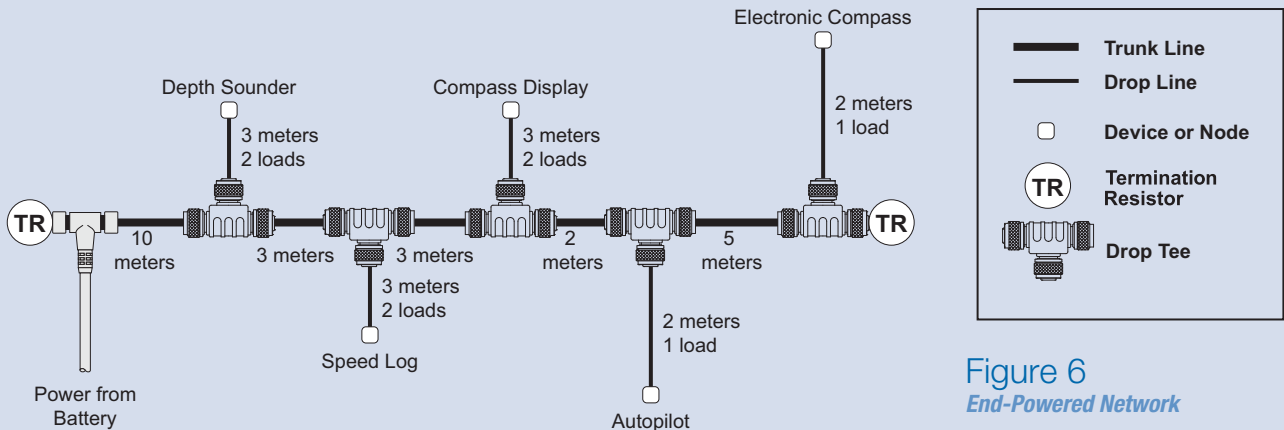
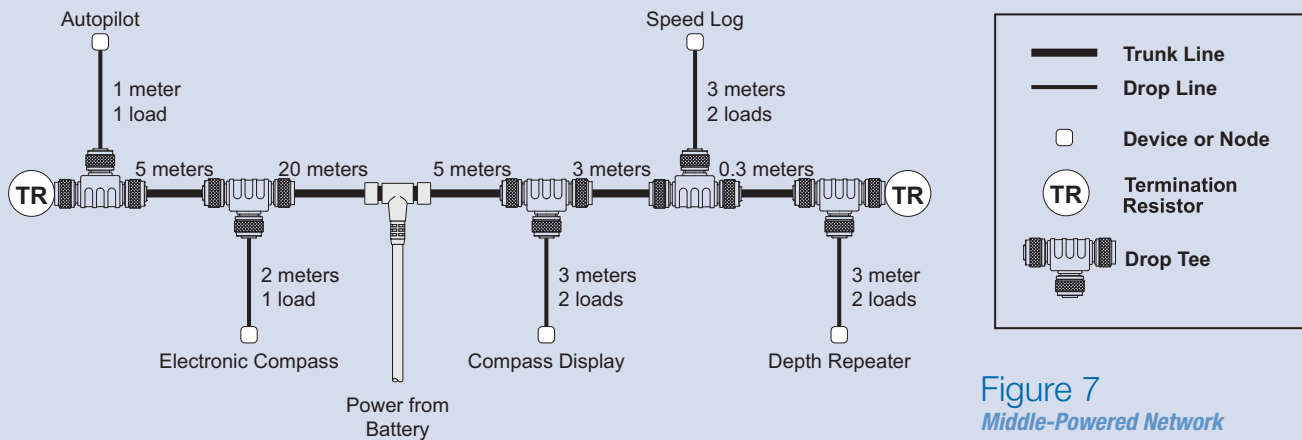

Figure 6
End-Powered Network



location. Grounding at more than one location may produce ground loops, which can cause problems with communications on the network. In addition to the ground wire, connect the drain or SHIELD wire at the supply ground location and NO other place.

5. Checking Your Network

Verify that the network has been correctly designed and installed by reviewing the following checklist:

- Number of devices does not exceed 50
- Maximum Mini cable distance between any two devices does not exceed 250 meters (820 feet)
- Maximum Micro/Mid cable distance between any two devices does not exceed 100 meters (328 feet)
- Maximum cumulative drop line length does not exceed 78 meters (256 feet)
- No drop should be greater than 6 meters (20 feet)
- Termination resistors are installed on both ends of the trunk
- The network is grounded at a single location
- The SHIELD wire is connected to a single point, the supply ground

If you are having difficulties with the network make sure to check the following most common network problems:

- More or less than two terminating resistors
- Loose connections, make sure that all connectors are securely fastened
- Excessive trunk line length-especially with Micro cable
- Excessive drop line cable length
- Improper shield and ground connection at the power supply
- Shorts and opens in field-attachable connectors
- Failure to perform power distribution calculations for new installations and when adding new devices
- Using a typical device current rather than maximum current for power distribution calculations

In order to insure the proper installation and configuration of an NMEA 2000® network, it is a good idea to have available at least one N2KMeter®. The N2KMeter® greatly simplifies network diagnostics and can detect many fault conditions including:

- Opens and shorts
- Incorrect topology
- Bad nodes
- Bad termination
- Improper shield connection
- Intermittent problems
- Excessive scan rate
- Common mode voltage