

OPERATION MANUAL

# ***YANMAR***

## ***MARINE DIESEL ENGINE***

**4JH3-TE/-TCE/-HTE/-DTE**

---

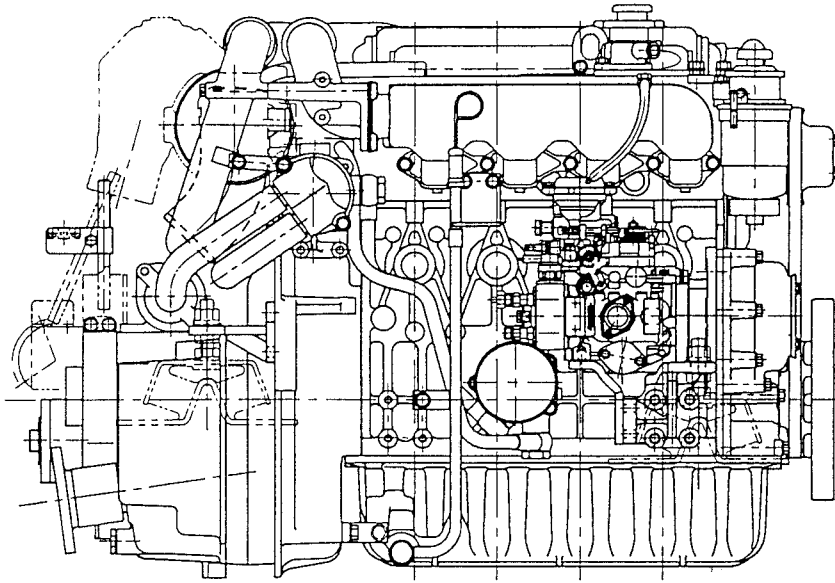

Model 4JH3-DTE(with KMH4A marine gear)



Be sure to read this manual for safe and proper operation.  
Store this manual carefully after use.

**Thank you for purchasing a Yanmar Marine Diesel Engine.**

## [ INTRODUCTION ]

- This Operation Manual describes the operation, maintenance and inspection, and handling precautions for the 4JH3-TE/-TCE/-HTE/-DTE Yanmar Marine Diesel Engine.
  1. FOR SAFE OPERATION : Safety indications, safety precautions, explanation and use.
  2. EXPLANATION OF PRODUCT : Specifications for this series and basic operation principles.
  3. PREPARATION FOR OPERATION : Fuel oil, lube oil, cooling water, etc. check and supply.
  4. OPERATION : Starting, speed adjusting, stopping and long-term storage.
  5. MAINTENANCE & INSPECTION : Periodic inspection, inspection items and time period, and detailed explanation.
  6. TROUBLE AND TROUBLESHOOTING : Simple troubles and table of troubleshooting measures.
- Read this Operation Manual carefully before operating the engine to ensure that it is used correctly and that it stays in the best possible condition.
- Keep this Operation Manual in a convenient place for easy access.
- If this Operation Manual is lost or damaged, order a new one from your dealer or distributor.
- If giving your engine to someone else, be sure to attach this Operation Manual.
- Constant efforts are made to improve the quality and performance of Yanmar products, so some details included in this Operation Manual may differ slightly from your engine. If you have any questions about this, please contact your Yanmar dealer or distributor.

**California  
Proposition 65 Warning**

Diesel engine exhaust and some of its constituents are known to the State of California to cause cancer, birth defects, and other reproductive harm.

**California  
Proposition 65 Warning**

Battery posts, terminals, and related accessories contain lead and lead compounds, chemicals known to the State of California to cause cancer and reproductive harm.

<b>1 FOR SAFE OPERATION</b> .....	<b>1</b>
1.1 Warning Symbols .....	1
1.2 Safety Precautions .....	2
1.3 Location of Product Safety Labels .....	4
<b>2 PRODUCT EXPLANATION</b> .....	<b>5</b>
2.1 Use & Driving System .....	5
2.2 Engine Specifications .....	6
2.2.1 4JH3-TE .....	6
2.2.2 4JH3-TCE .....	7
2.2.3 4JH3-HTE .....	8
2.2.4 4JH3-DTE .....	9
2.3 Names of Parts .....	10
2.4 Major Servicing Parts .....	11
2.5 Operation Equipment .....	12
2.5.1 Instrument Panel .....	12
2.5.2 Remote Control Handle .....	15
<b>3 BEFORE OPERATION</b> .....	<b>18</b>
3.1 Fuel Oil, Lube Oil and Cooling Water .....	18
3.1.1 Fuel Oil .....	18
3.1.2 Lube oil .....	19
3.1.3 Cooling Water .....	19
3.2 Supplying Fuel .....	20
3.2.1 Filling the Fuel Tank .....	20
3.2.2 Bleeding the Fuel System .....	20
3.3 Supplying Engine Lube Oil .....	21
3.4 Supplying Marine Gear Lube Oil .....	21
3.5 Supplying Cooling Water .....	22
3.6 Cranking .....	23
3.7 Checking the Lube Oil and Cooling Water .....	23
<b>4 HOW TO OPERATE</b> .....	<b>24</b>
4.1 Inspection Before Starting .....	24
4.2 Checking the Illumination Lamps of the Panel Meters .....	26
4.2.1 Checking the Illumination Lamps of the Panel Meters .....	26
4.2.2 Checking the Alarm Devices .....	26
4.2.3 Checking the Panel Meters .....	26
4.3 starting .....	27
4.3.1 Daily Starting .....	27
4.3.2 Starting Under Low Temperature Conditions .....	27
4.3.3 Restarting After Starting Failure .....	27
4.3.4 After the Engine has Started .....	28
4.4 Adjusting the Engine Speed .....	28
4.5 Clutch Operation for the Marine Gear .....	29
4.5.1 Forward, Neutral, Reverse .....	29
4.5.2 Switching to Trawling (Available for KMH4A only) .....	29
4.6 Check During Operation .....	30
4.7 Stopping the Engine .....	31
4.8 Operation Procedure .....	32
4.9 Long-Term Storage .....	33
4.9.1 Before storing for long periods of time, perform the following. ....	33
4.9.2 Checking the Engine for Reuse After a Long Storage Period .....	34

<b>5 MAINTENANCE &amp; INSPECTION</b> .....	<b>35</b>
5.1 List of Periodic Inspections .....	36
5.2 Periodic Inspection Items .....	37
5.2.1 Inspection After Initial 50Hrs. Operation .....	37
5.2.2 Inspection Every 50 Hours .....	39
5.2.3 Inspection Every 250 Hrs. or 1 yr. ....	41
5.2.4 Inspection Every 500 Hrs.or 2 yrs. ....	44
5.2.5 Inspection Every 1000 Hrs. or 4 yrs. ....	45
<b>6 TROUBLE AND TROUBLESHOOTING</b> .....	<b>47</b>
6.1 Simple problems and the appropriate countermeasures .....	47
6.2 Emergency Repairs for Marine Gear Trouble .....	49
6.3 Consulting Your Yanmar Dealer or Distributor .....	50
<b>7 SYSTEM DIAGRAM</b> .....	<b>52</b>
7.1 Wiring diagram .....	52
7.1.1 B type Instrument Panel .....	52
7.1.2 C type / C type × B type(No.2 station) Instrument Panel .....	54
7.1.3 New B type Instrument Panel .....	56
7.1.4 New C type / New C type × New B type(No.2 station) .....	58
7.1.5 Instrument Panel .....	58

# 1. FOR SAFE OPERATION

---

Following the precautions described in this manual will enable you to use this engine with complete satisfaction. Failure to observe any of the rules and precautions, however, may result in injury, burns, fires, and engine damage. Read this manual carefully and be sure you fully understand it before beginning operation.

## 1.1 Warning Symbols

---

These are the warning signs which are used in this manual and on the products. Pay special attention to them.

### **DANGER**

**DANGER**- Indicates an imminently hazardous situation which, if not avoided, **WILL** result in death or serious injury.

### **WARNING**

**WARNING**- Indicates a potentially hazardous situation which, if not avoided, **COULD** result in death or serious injury.

### **CAUTION**

**CAUTION**- Indicates a potentially hazardous situation which, if not avoided, **MAY** result in minor or moderate injury. It may also be used to alert against unsafe practices.

- The descriptions captioned by **NOTICE** are for the particularly important cautions for handling. If you ignore them, the performance of your machine may deteriorate leading to trouble.

## 1.2 Safety Precautions

(Observe these instructions for your own safety.)

### Precautions for Operation

#### **⚠ DANGER**



#### **Burns from Scalding**

- Never remove the filler cap of the fresh water cooler while the engine is still hot. Steam and hot water will spurt out and seriously burn you. Wait until the water temperature has dropped, then wrap a cloth around the cap and loosen it slowly.
- After inspection, refasten the filler cap firmly. If the cap is not secure, steam or scalding water may be emitted during operation causing burns.

#### **⚠ DANGER**

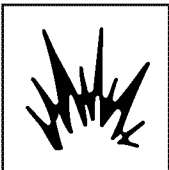

#### **Proper Ventilation of the Battery Area**

- Be sure the area around the battery is well-ventilated and there is nothing which could start a fire. During operation and charging, hydrogen gas is emitted from the battery and can be easily ignited.

#### **⚠ DANGER**



#### **Fires from Oil Ignition**

- Be sure to use the correct type of fuel when refueling. Mistakenly filling with gasoline or the like will result in ignition.
- Be sure to stop the engine before refueling. If you spill fuel, wipe such spillage carefully.
- Never place oils or other flammable material close to the engine as this could result in ignition.

#### **⚠ WARNING**



#### **Exhaust Gas Poisoning**

- Be sure to establish good ventilation in the engine room with windows, vents, or other ventilation equipment. Check again during operation to be sure that ventilation is good. Exhaust gas contains poisonous carbon monoxide and should not be inhaled.

#### **⚠ WARNING**



#### **Moving Parts**

- Do not touch the moving parts of the engine (propeller shaft, V-belt, PTO-pulley, etc.) during operation or let your clothing get caught in them as this can result in injury.
- Never operate the engine without the covers on the moving parts.
- Check before starting the engine to see that any tools or cloths used in maintenance have been removed from the area.

#### **⚠ CAUTION**

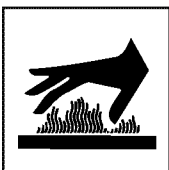

#### **Burns from Contact with Hot Engine Parts**

- The whole engine is hot during operation and immediately after stopping. The turbocharger, exhaust manifold, exhaust pipe, and engine are very hot. Never touch these parts with your body or clothing.

**⚠ WARNING****Alcohol**

- Never operate the engine while you are under the influence of alcohol or when you are ill or feel unwell as this results in accidents.

**Safety Precautions for Inspection****⚠ DANGER****Battery Fluid**

- Battery fluid is diluted sulfuric acid. It can blind you if it gets in your eyes, or burn your skin. Keep the fluid away from your body. Wash it off immediately with a large quantity of fresh water if you get any on you.

**⚠ WARNING****Fire due to Electric Short-Circuits**

- Always turn off the battery switch or detach the earth cable (-) before inspecting the electrical system. Failure to do so could cause short-circuiting and fires.

**⚠ WARNING****Precautions for Moving Parts**

- Stoop the engine before you service it. If you must inspect while the engine is operating, never touch moving parts. Keep your body and clothing well clear of all moving parts as this could result in injury.

**⚠ CAUTION****Precautions for Removing Hot Oil and Water to Prevent Burns**

- If extracting oil from the engine while it is still hot, do not let the oil splash on you.
- Wait until the temperature has dropped before removing cooling water from the engine to avoid getting scalded.

**NOTICE:*****Do not alter the diesel engine.***

*Rebuilding the engine or altering parts to increase the speed or the amount of fuel discharged, etc. will make operation unsafe, and result in damage and shortening of engine life.*

**NOTICE:*****Disposal of waste materials***

- *Put oil or liquids to be disposed in a container. Never dispose of waste oil or other fluids outside, in a sewer, river, or the sea.*
- *Treat waste materials safely observing all regulations and laws. Ask a waste recovery company to collect and dispose of it.*

## 1.3 Location of Product Safety Labels

To insure safe operation, product safety labels have been attached. Their location is shown in the diagram below. Keep the labels from becoming dirty or torn and replace them if they are lost or damaged. Also replace labels when parts are replaced, ordering them in the same way as for the parts.

Product Safety Labels, Parts Code Numbers	
1	128377-07350
2	128296-07260
3	128296-07300
4	196630-12980

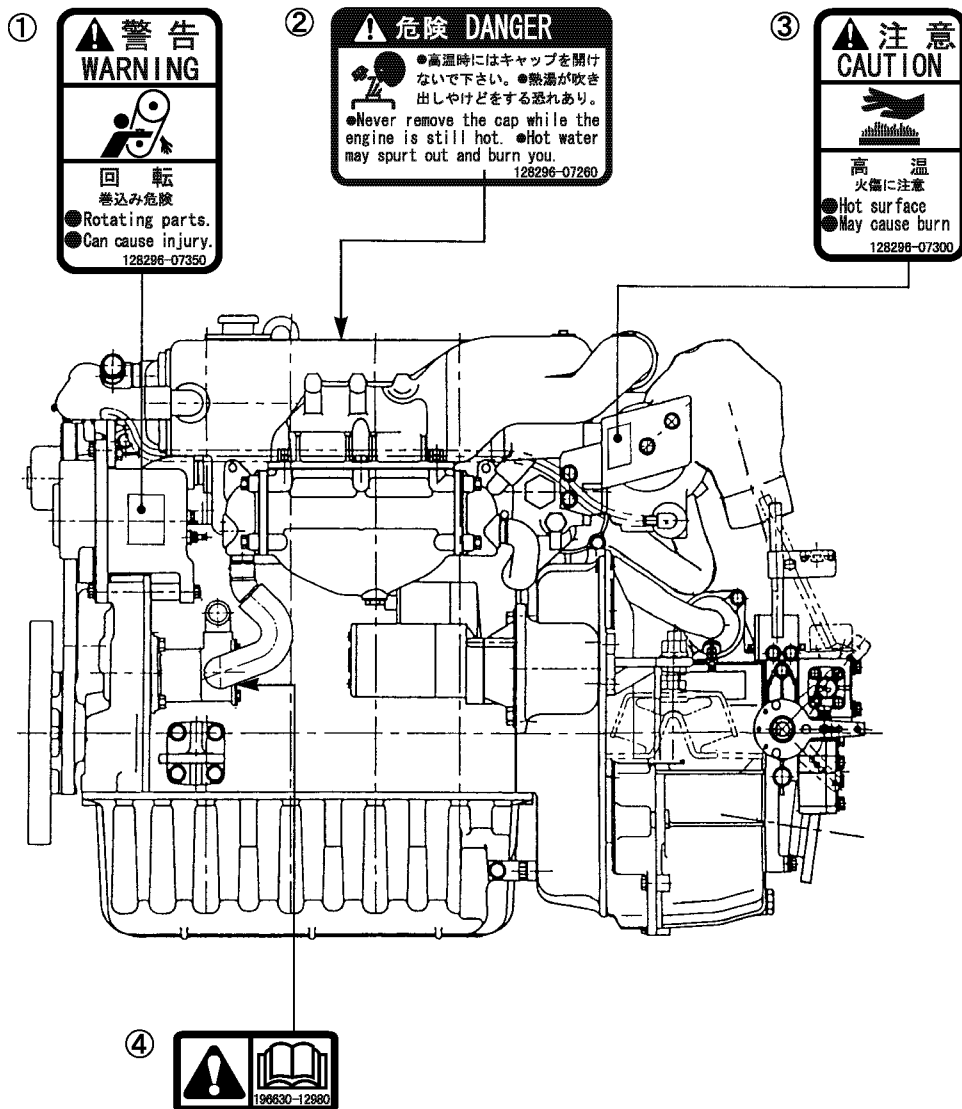

The above diagram shows a side view of the engine.



## 2. PRODUCT EXPLANATION

### 2.1 Use & Driving System

This is light, compact diesel engine for use in pleasure boats. The engine is equipped with a turbocharger and intercooler which insures maximum output while preserving lightness and compact size. (The 4JH3-TE /-TCE are equipped with the turbocharger only.)

Power output for this group of engines increases progressively from 4JH3-TE(4JH3-TCE), 4JH3-THE to 4JH3-DTE.

In case of engine with marine gear, connect the propeller shaft to the marine gear output shaft. The 4JH3-TCE is with drive SD40-4T. For the sail drive, please refer to its operation manual.

The different types of applicable marine gears for each engine are shown below.

Engine Marine gear	4JH3-TE	4JH3-THE	4JH3-DTE	Note
KBW21	○	○	×	○ : Applicable × : Not applicable
KM4A	○	○	×	
KMH4A	○	○	○	

The installation, fitting and surveying of this engine all require specialized knowledge and engineering skills. Additionally, boat and engine inspection may be required by the laws of some countries. Consult Yanmar's local subsidiary in your region or your distributor or dealer.

In order to get full performance from your engine, it is imperative that the size and structure of the boat be suited to the engine. It is equally important to use the correct driving device and a propeller of the appropriate size and specifications.

The engine must be installed correctly with safe cooling water and exhaust piping and electrical wiring. The PTO work should be easy to use for onboard equipment.

Consult your Yanmar dealer or distributor when selecting optional parts. Optional parts selections should take into account operational and surrounding conditions.

This Operation Manual explains the basic points for standard operation. Variations are explained under the specially marked sections.

This operation Manual explains the basic points for standard operation. Variations are explained under the letter emblems for easy reference.

**MODEL** : Explanation of indicated model only.

**OPTION** : Explanation of optional parts.

**CUSTOMER** : Explanation of use of parts from other boat manufacturers.

Where there are no letter emblem sections the explanation applies to all models.

Explanation for driving devices, propellers, etc. and optional parts are not included, and special attention should be paid to the explanations and safety precautions in the operation manuals provided by the boat and equipment manufacturers.

## 2.2 Engine Specifications

### 2.2.1 4JH3-TE

Engine model		4JH3-TE						
Use		Pleasure boat						
Type		Vertical water-cooled 4-cycle diesel engine						
No. of cyl.-bore×stroke		4-φ84×90						
Displacement L		1.995						
Aspiration		Turbocharged						
Cont. rating kW{hp}/rpm		50.7(69) / 3700						
Max. output kW{hp}/rpm (Crankshaft)		*55.2(75)/3800 **53.5(72.8)/3800						
High idling rpm		4300±25						
Low idling rpm		700±25						
Combustion system		Direct injection						
Starting system		Electric starting						
Cooling system		Constant high temperature fresh water cooling						
Lubricating system		Forced lubrication system with trochoid pump						
Marine gear	Model	KBW21		KM4A		KMH4A		-
	Type	Mechanical wet multiple disk clutch input/output eccentric parallel drive		Mechanical wet cone clutch 7° Down angle drive		Hydraulic wet multiple disk clutch 8° Down angle drive		
	Reduction ratio (Ahead/Astern)	2.17/3.06	2.62/3.06	1.47/1.47 2.63/2.63	2.14/2.14 3.30/3.30	2.04/2.04	2.45/2.45	
Direction of rotation	Crankshaft	Counterclockwise (Viewed from stern side)						
	Propeller shaft	Clockwise (Viewed from stern side)						
Fuel injection pump		Bosh-distributor type Model VE(ZEXEL)						
Fuel injection valve		Pinhole injection nozzle YDLLA-P(5-0.22×150°)						
Turbocharger		RHB52(IHI) Water cooled and forced lubrication system						
Elec. devices	Starter	DC12V-1.4kW						
	Alternator	DC12V-55A						
Lube oil capacity (raked angle) L	Engine	Oilpan	5.2(7°)		6.4(0°)		Refer to the left	
		All	6.3(7°)		7.5(0°)			
	Marine gear	1.2	1.3	2.0		-		
Cooling water capacity L	Fresh water tank	6.0						
	Subtank	0.8						
Dimensions (L×W×H) mm		898×560×635	888×565×635	886×565×635	763×566×635			
Engine installation style		On the flexible rubber engine mount						
Recommended battery capacity		12V-120A or greater						
Recommended engine room ventilator		12m <sup>3</sup> /min or greater						
Dry mass kg		249	247	250	219			
<b>Note:</b> 1. Rating condition : ISO 3046-1, 8665 2. 1hp=0.7355kW 3. Fuel condition : Density at 15°C=0.860, Fuel oil temperature * :25°C at the fuel injection pump inlet ** : ISO 8665(Fuel oil temp. 40°C at the fuel injection pump inlet)								

## 2.2.2 4JH3-TCE

Engine model		4JH3-TCE	
Use		Pleasure boat (Sailing boat)	
Type		Vertical water-cooled 4-cycle diesel engine	
No. of cyl.-borexstroke	mm	4-φ84×90	
Displacement	L	1.995	
Aspiration		Turbocharged	
Cont. rating	kW{hp}/rpm	50.7(69)/3700	
Max. output	kW{hp}/rpm (Crankshaft)	*55.2(75)/3800 **53.5(72.8)/3800	
High idling	rpm	4300±25	
Low idling	rpm	700±25	
Combustion system		Direct injection	
Starting system		Electric starting	
Cooling system		Constant high temperature fresh water cooling	
Lubricating system		Forced lubrication system with trochoid pump	
Sail drive	Model		SD40-4T
	Type		Mechanical wet cone clutch
	Reduction ratio		Refer to the operation manual for the sail drive
Direction of rotation	Crankshaft		Counterclockwise(Viewed from stern side)
	Propeller		Refer to the operation manual for the sail drive
Fuel injection pump		Bosh-distributor type Model VE(ZEXEL)	
Fuel injection valve		Pinhole injection nozzle YDLLA-P(5-0.22×150°)	
Turbocharger		RHB52(IHI) Water cooled and forced lubrication system	
Elec. devices	Starter		DC12V-1.4kW
	Alternator		DC12V-55A
Lube oil capacity (raked angle)	L	Engine	Oilpan
			All
		Drive	Refer to the operation manual for the sail drive
Cooling water capacity	L	Fresh water tank	
		Subtank	
Dimensions (L×W×H)		mm	1086×565×1238(Propeller shaft center)
Engine installation style		On the flexible nubber engine mount	
Recommended battery capacity		12V-120A or greater	
Recommended engine room ventilator		12m <sup>3</sup> /min or greater	
Dry mass		kg	219(Engine)
<b>Note:</b>			
1. Rating condition : ISO 3046-1, 8665			
2. 1hp=0.7355kW			
3. Fuel condition : Density at 15°C=0.860, Fuel oil temperature *:25°C at the fuel injection pump inlet			
** : ISO 8665(Fuel oil temp. 40°C at the fuel injection pump inlet)			

## 2.2.3 4JH3-HTE

Engine model		4JH3-HTE						
Use		Pleasure boat						
Type		Vertical water-cooled 4-cycle diesel engine						
No. of cyl.-bore×stroke	mm	4-φ84×90						
Displacement	L	1.995						
Aspiration		Turbocharged						
Cont. rating	kW{hp}/rpm	67.7(92)/3700						
Max. output	kW{hp}/rpm (Crankshaft)	*73.6(100)/3800 **71.4(97)/3800						
High idling	rpm	4300±25						
Low idling	rpm	700±25						
Combustion system		Direct injection						
Starting system		Electric starting						
Cooling system		Constant high temperature fresh water cooling						
Lubricating system		Forced lubrication system with trochoid pump						
Marine gear	Model	KBW21		KM4A		KMH4A		-
	Type	Mechanical wet multiple disk clutch input/output eccentric parallel drive		Mechanical wet cone clutch 7° Down angle drive		Hydraulic wet multiple disk clutch 8° Down angle drive		
	Reduction ratio (Ahead/Astern)	2.17/3.06	2.62/3.06	1.47/1.47 2.63/2.63	2.14/2.14 3.30/3.30	2.04/2.04	2.45/2.45	
Direction of rotation	Crankshaft	Counterclockwise (Viewed from stern side)						-
	Propeller shaft	Clockwise (Viewed from stern side)						
Fuel injection pump		Bosh-distributor type Model VE(ZEXEL)						
Fuel injection valve		Pinhole injection nozzle YDLLA-P(5-0.25×150°)						
Turbocharger		RHB52(IHI) Water cooled and forced lubrication system						
Elec. devices	Starter	DC12V-1.4kW						
	Alternator	DC12V-55A						
Lube oil capacity (raked angle)	L Engine	Oilpan	5.2(7°)		6.4(0°)		Refer to the left	
		All	6.3(7°)		7.5(0°)			
	Marine gear	1.2	1.3	2.0		-		
Cooling water capacity	L Fresh water tank	7.2						
	Subtank	0.8						
Dimensions (L×W×H)	mm	898×581×660	888×580×660	886×581×635	763×581×660			
Engine installation style		On the flexible rubber engine mount						
Recommended battery capacity		12V-120A or greater						
Recommended engine room ventilator		16m <sup>3</sup> /min or greater						
Dry mass	kg	258	256	259	228			
<b>Note:</b>								
1. Rating condition : ISO 3046-1, 8665								
2. 1hp=0.7355kW								
3. Fuel condition : Density at 15°C=0.860, Fuel oil temperature * :25°C at the fuel injection pump inlet								
** : ISO 8665(Fuel oil temp. 40°C at the fuel injection pump inlet)								

## 2.2.4 4JH3-DTE

Engine model		4JH3-DTE				
Use		Pleasure boat				
Type		Vertical water-cooled 4-cycle diesel engine				
No. of cyl.-bore×stroke	mm	4-φ84×90				
Displacement	L	1.995				
Aspiration		Turbocharged				
Cont. rating	kW{hp}/rpm	85.3(116)/3700				
Max. output	kW{hp}/rpm (Crankshaft)	*91.9(125)/3800 **89.1(121.3)/3800				
High idling	rpm	4300±25				
Low idling	rpm	700±25				
Combustion system		Direct injection				
Starting system		Electric starting				
Cooling system		Constant high temperature fresh water cooling				
Lubricating system		Forced lubrication system with trochoid pump				
Marine gear	Model	KMH4A			-	
	Type	Hydraulic wet multiple disk clutch 8° Down angle drive				
	Reduction ratio (Ahead/Astern)	2.04/2.04, 2.45/2.45				
Direction of rotation	Crankshaft	Counterclockwise (Viewed from stern side)			-	
	Propeller shaft	Clockwise (Viewed from stern side)				
Fuel injection pump		Bosh-distributor type Model VE(ZEXEL)				
Fuel injection valve		Pinhole injection nozzle YDLLA-P(5-0.26×150°)				
Turbocharger		RHB52(IHI) Water cooled and forced lubrication system				
Elec. devices	Starter	DC12V-1.4kW				
	Alternator	DC12V-55A				
Lube oil capacity (raked angle)	Engine	Oilpan	6.4(0°)		Refer to the left	
		All	7.5(0°)			
	Marine gear	2.0		-		
Cooling water capacity	Fresh water tank	7.2				
	Subtank	0.8				
Dimensions(L×W×H)		mm	898×581×660	888×581×660	886×581×635	763×581×660
Engine installation style		On the flexible rubber engine mount				
Recommended battery capacity		12V-120A or greater				
Recommended engine room ventilator		20m <sup>3</sup> /min or greater				
Dry mass	kg	260		229		
<b>Note:</b>						
1. Rating condition : ISO 3046-1, 8665						
2. 1hp=0.7355kW						
3. Fuel condition : Density at 15°C=0.860, Fuel oil temperature * :25°C at the fuel injection pump inlet						
** : ISO 8665(Fuel oil temp. 40°C at the fuel injection pump inlet)						

## 2.3 Names of Parts

- Operation Side (Right side as viewed from the propeller.) Contains the main parts necessary for operation

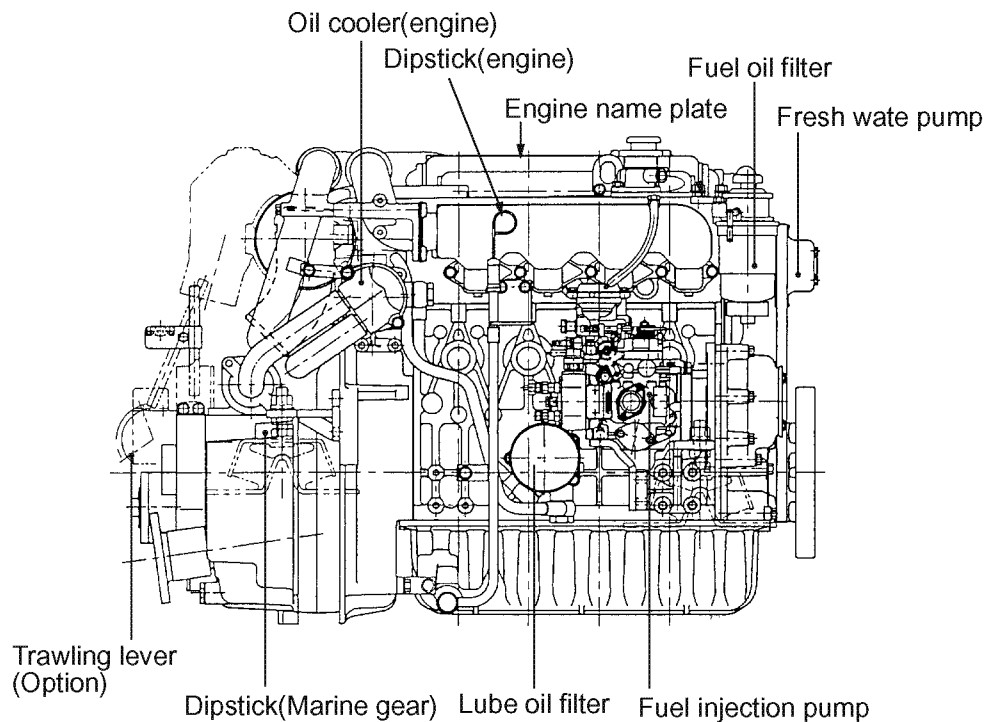

- Non-Operation Side

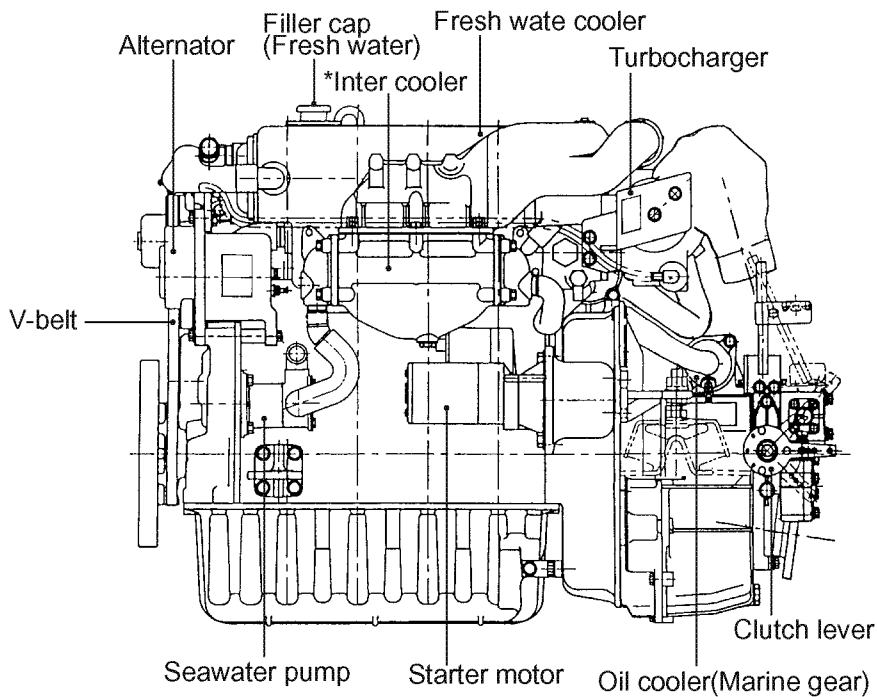

**NOTE:**

The 4JH3-DTE engine with KM4A is used as the example for the above drawings.  
 The 4JH3-TE is not equipped with an intercooler (indicated by \* mark in the above).

## 2.4 Major Servicing Parts

Name of part	Function
Fuel filter	Removes dust and water from fuel. The filter is a cartridge type, and the inner element should be replaced before clogging occurs. A water separator is on the bottom of the filter and should be drained periodically.
Fuel priming pump	This is a manual fuel pump. Moving the knob on the top of the fuel filter feeds the fuel. The pump is also used to bleed air from the fuel system.
Fuel feed pump	This is a mechanical pump used to feed fuel to the fuel injection pump. It is built into the fuel injection pump.
Filler port (engine oil)	Filler port for engine lube oil.
Filler port (marine gear oil)	Filler port for marine gear lube oil. Located on the top of the marine gear case.
Dipstick (engine oil)	Gauge stick for determining the level of the engine oil.
Lube oil filter	Filters fine metal fragments and carbon from the lube oil. The filter is a cartridge type, and the inner element should be replaced before clogging occurs.
[ Cooling Water System ]	This engine is cooled by 2 cooling systems: fresh water and seawater.
Fresh water cooler (Built-in fresh water tank)	The tank stores the fresh cooling water and is built into the fresh water cooler. Cooling seawater passes through the fresh water cooler to cool the fresh water by heat exchange.
Cooling water pump	Located on top of the fresh water tank the filler cap closes the filler port. It has two pressure regulating valves (pressure valve and vacume valve).
Filler cap	When the cooling water temperature rises, the pressure inside the fresh water tank increases causing the pressure valve in the filler cap to open. Hot water and steam pass through a rubber hose to the subtank to condense the hot water. (The filler port and the subtank are connected by a rubber hose.)
Subtank	When the load is reduced and the cooling water temperature falls, the pressure in the fresh water tank is lowered, and this activates the vacume valve in the filler cap causing the cool water in the subtank to return to the fresh water tank. This process reduces the consumption of cooling water.
Oil cooler (engine oil)	This heat exchanger cools the engine oil with seawater.
Oil cooler (marine gear oil)	This heat exchanger cools high temp. marine gear oil with seawater.(KBW21,KMH4A)
Turbocharger	With the pressurized intake air feeding device the exhaust gas turbine is rotated by exhaust gas, and the power is used to rotate the blower This pressurizes the intake air for sending to the cylinder gives high power output.
Intercooler	This heat exchanger cools the pressurized intake air from the turbocharger with seawater and increases the intake air quantity.
Starter motor	This is a DC motor for electrical starting. Electric current causes the pinion gear to engage with the ring gear on the flywheel to start the engine.
Alternator	This is a AC generator built in the rectifier and regulator which rotates by V-belt drive to charge the battery during operation.

## 2.5 Operation Equipment

Explanation of the equipment used to operate the engine.

### 2.5.1 Instrument Panel

**OPTION**

The instrument panel is located in the cockpit, separate from the engine. The following instruments enable you to start and stop the engine and to monitor its condition during operation.

◆B type

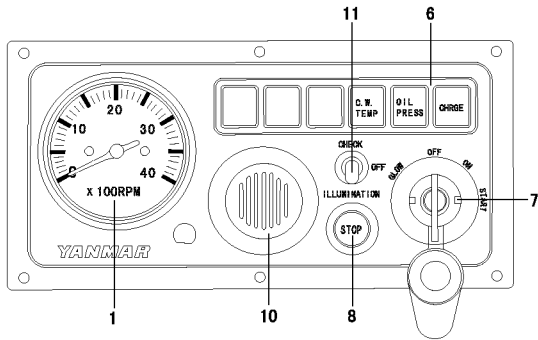

◆New B type

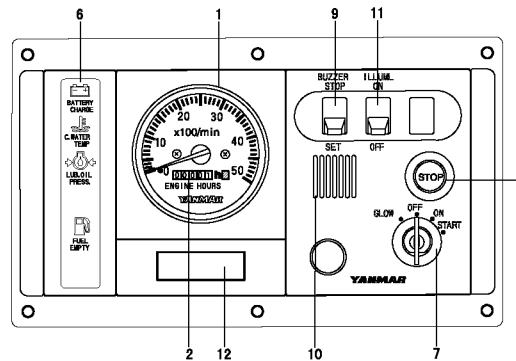

◆C type

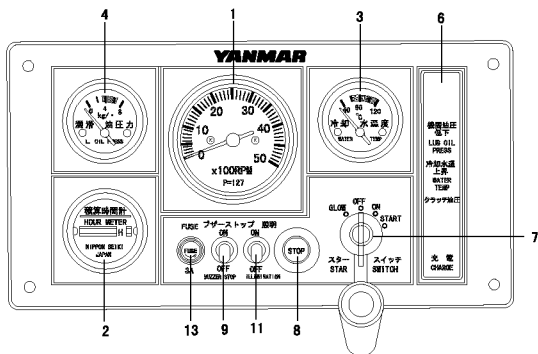

◆New C Type

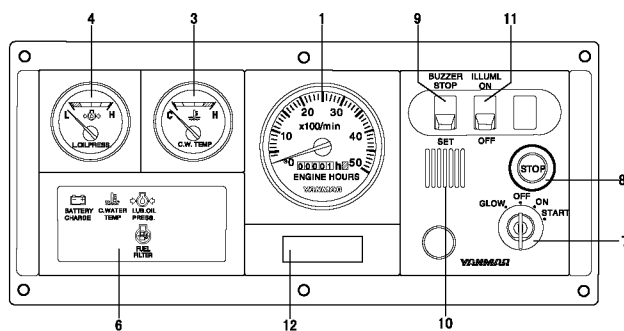

No.	Model	B	C	New B	New C
7	Switch unit	○	○	○	○
8		○	○	○	○
10		○	○	○	○
9		×	○	○	○
11		○	○	○	○
11		○	×	×	×
6	Alarm lamp unit	○	○	○	○
		○	○	○	○
		○	○	○	○
		×	×	×	○
		×	×	△	○
		×	×	○	△
1	Tachometer	×	×	○	○
		○	○	-	-
2	Hour meter	×	○	-	-
4	Sub meter unit	×	○	×	○
		×	○	×	○
12	Clock unit	×	×	△	△

○: Available    ×: Not available    △: Optional



## (1) Meters

The following meters are located in the upper center part of the instrument panel.

- ◆ B/C and New B/C type panels use analog electric systems and have a pointer indicator.

Turn the panel light switch (illumination switch) ON for easy viewing.

- Tachometer  
The engine speed is indicated. Engine speed can be monitored.
- Hour meter  
The number of hours of operation is indicated, and can be used as a guide for periodic maintenance checks.
- Cooling Water Temperature Meter (C, New C)  
The cooling water temperature is indicated. Enables monitoring of the cooling condition of the engine.
- Lube Oil Pressure Meter (C, New C)  
The engine oil pressure is indicated.  
Enables monitoring of the condition of the engine's lube oil.

## (2) Alarm Devices

When there is some problem during operation, the alarm buzzers and lamps will come on.

- Alarm buzzers  
When the various alarm lamps come on, the alarm buzzers will come on at the same time and continue to sound. However, no alarm buzzer will sound when the charge lamp comes on.
- Buzzer stop switch  
When the buzzer sound is no longer necessary, it can be turned off with the Buzzer stop switch.
- Alarm lamps  
The alarm monitor window indicates the trouble spot when one of the symbols shown below lights up. When operation is normal the alarm lights are off; however, should some problem arise, the sensors will pick it up and cause the light behind the appropriate symbol to come on.



### 1. BATTERY CHARGE

When the charge is abnormal, the lamp will come on. When charging begins the lamp will go off. (Alarm buzzer will not sound when the lamp comes on.)



### 2. C.WATER TEMP

When the temperature of the cooling fresh water exceeds the maximum (95 degree C or higher), the lamp will light. Continuing operation at temperatures exceeding the maximum will result in damage and seizure. Check the load and the cooling system for any abnormalities.



### 3. LUB.OIL PRESS.

When the lube oil pressure falls below specified oil pressure sensor will detect this and the lamp will come on. Continuing operation with insufficient oil will result in damage and seizure. Check the oil level.



### 4. FUEL FILTER (New C)

When the drain inside the water separator in the fuel filter becomes excessive, the sensor will cause the lamp to come on. Clean out the drain in the water separator. If operation is continued without cleaning, it will become impossible to feed fuel to the engine or damage and seizure of the fuel injection pump will result.



### 5. SAIL DRIVE LEAK (New C, New B(optional))

When the seal rubber attached between sail-drive and hull is damaged and sea water leaks into between the seal rubbers, the lamp comes on. If this happens, stop the engine and quickly return to the nearest port under sail for repairs.



### 6. FUEL EMPTY (New B, New C(optional))

When the amount of fuel in the tank is insufficient, the sensor will activate the lamp. Fill with fuel.

### (3) Starter Switch

This is the switch for starting engine operation. It is a rotary-type 3-step switch. Position is changed by turning the key in the switch.

- OFF** is the position where the engine is stopped. All current is cut off. The key can be inserted and removed in this position.
- ON** is the position for operation. Current flows to the instruments and alarm devices.
- START** is the position for starting. When the starter motor turns, the engine starts. The key returns automatically to the ON position when you remove your hand.

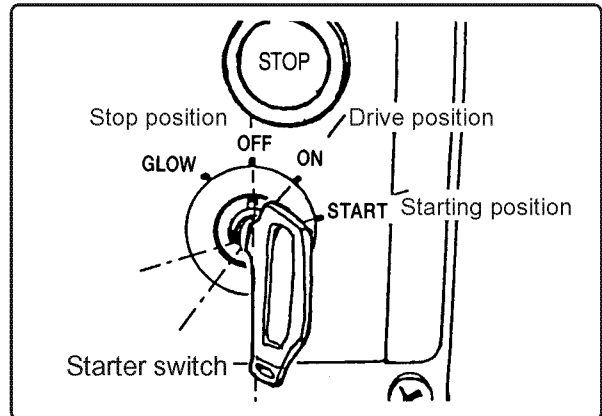

**GLOW** is the position for turning on the air heater. The air heater (OPTION) aids starting during cold conditions by warming up the intake air before starting.

Note: Neutral Safety Switch

OPTION for KM4A KMH4A

The engine can only be started when the clutch is in Neutral. If an attempt is made to start the engine in any other position, the neutral safety switch will operate to make starting impossible.

### (4) Stop button

The engine is stopped by pushing the stop button on the right of the control panel. When the stop button is pushed, the solenoid valve on the fuel injection pump works to cut off the fuel supply and stop the engine. Continue to push the stop button until the engine has come to a complete stop.

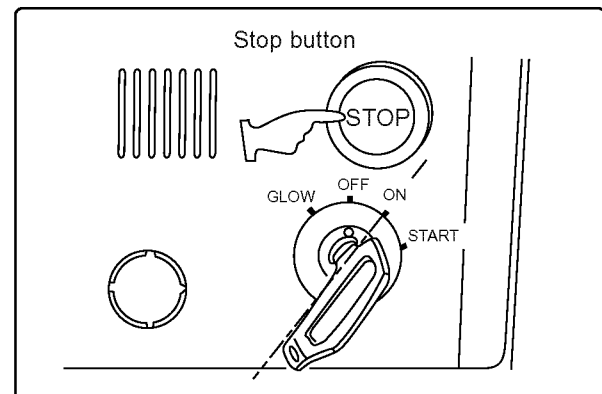

### 2.5.2 Remote Control Handle

This engine is controlled by the remote control handle located in the cockpit. The speed control lever on the engine side and clutch lever on the marine drive are connected by remote control cable with the various remote control handles in the cockpit (We recommend you a single handle remote control device). There are the following kinds of remote control handles. When using other kinds of remote control devices, consult their operation manuals.

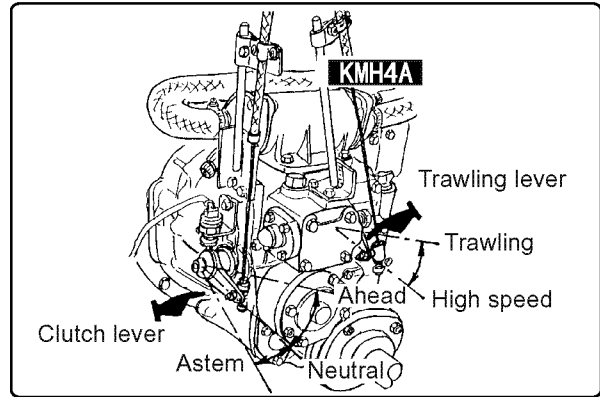
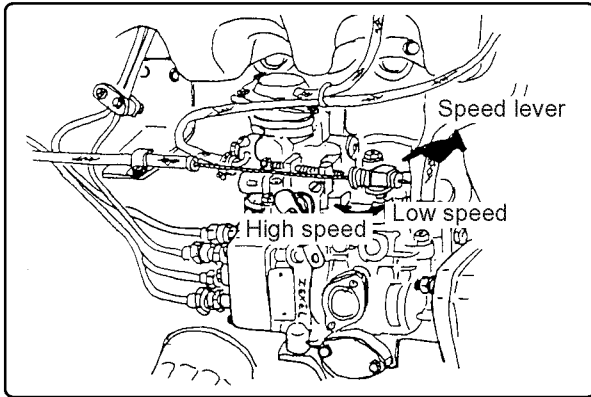

#### (1) Morse Remote Control Handle

**OPTION**

This is a single-handle remote control device connected by a remote control cable. It operates the clutch to neutral, forward, and reverse and controls the engine speed.

**Model MT-3** : Top mounting type.

**Model MV** : Side mounting type.

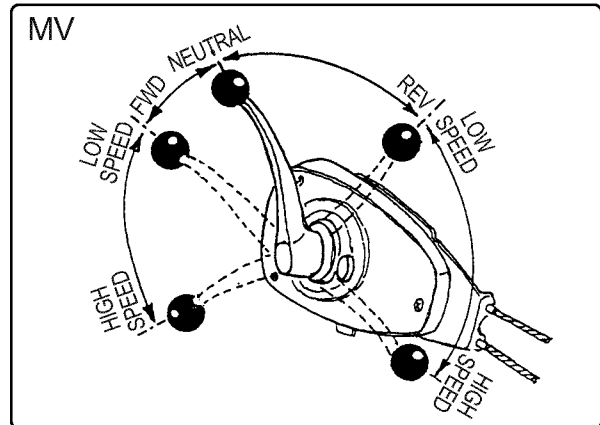
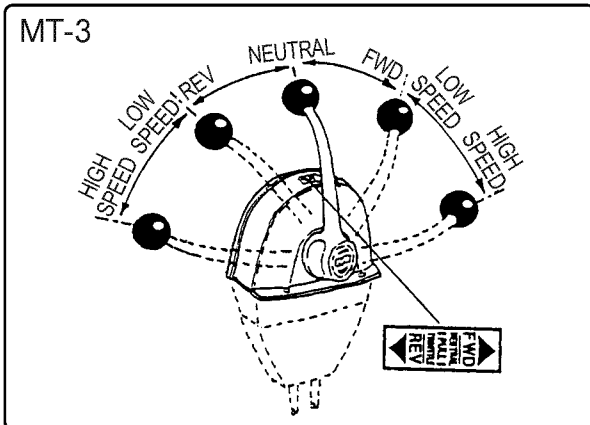

The labels for operation on the handle are:

- △FWD: Forward
- NEUTRAL: Clutch disengaged position
- THROTTLE: Position to reduce engine speed
- ▽REV: Reverse

**Operation of the handle is as follows:**

- Starting and stopping  
Put the handle in NEUTRAL.  
This puts the clutch in the cut-off position (stop) and idles the engine at a low speed.
- Forward  
Move the handle from NEUTRAL to ΔFWD(forward).  
This engages the clutch in forward and simultaneously increases the engine speed.  
Pushing the handle further in the same direction increases engine speed to full speed.
- Reverse  
Move the handle from NEUTRAL to ∇REV(reverse).  
This engages the clutch in reverse and simultaneously increases the engine speed.  
Pushing the handle further in the same direction increases engine speed to full speed.
- Free throttle operation  
When the boat is stopped (clutch is in neutral position), the idling speed of the engine can be increased in the following manner.

1. Leave the handle lever in **NEUTRAL**.
2. Disengage the clutch.

**MT-3:** Pull out the handle lever all the way.

**MV:** Pull out the free throttle button next to the handle lever.

3. With the lever or button pulled out, move the handle lever in either the forward or reverse direction to increase idling speed.

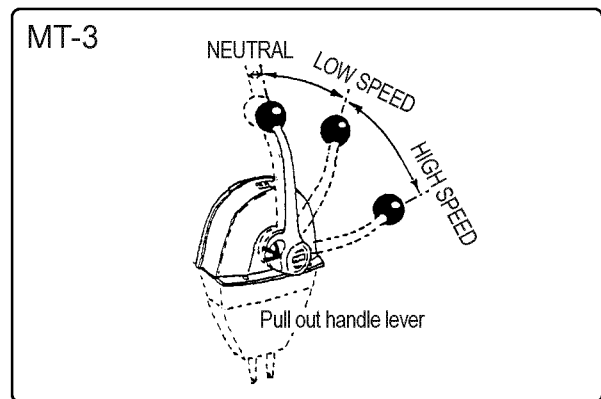

- Returning to normal operation from free throttle operation.

**MT-3:** Return the handle lever to NEUTRAL. The lever will return automatically to the normal position.

**MV:** Return the handle lever to NEUTRAL and push the free throttle button in.

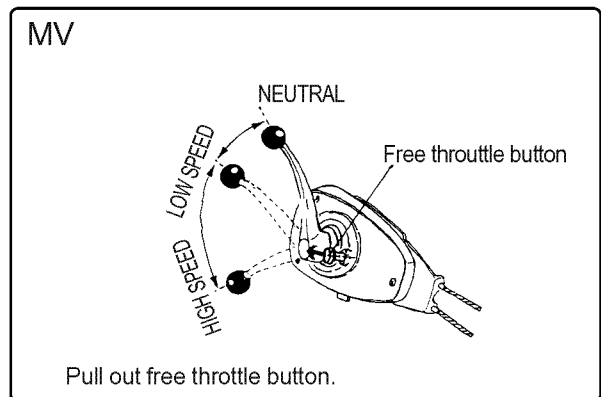

## (2) Trawling Handle

The trawling control is a single remote control handle. The marine gear trawling lever operates by remote control cable.

The operation labels on the handle are:

H: Highest trawling speed and normal (not trawling) operation position.

L: Lowest trawling speed position.

Only operate with the trawling handle at the low engine speed, 1000 rpm or less.

While trawling operation, the marine gear clutch is at half clutching running and the propeller speed is very slow slipping against the clutch disk.

Do not operate at over 1000rpm engine speed.

1. Loosen the handle grip by turning it to the left. This frees the handle.
2. Move the handle toward L(low speed) and position at the desired speed. Turn the handle grip to the right to secure it.
3. Before returning to normal high speed operation, be sure to position the handle in H(high speed) tightening the grip by turning it to the right to secure the handle in place.

### NOTICE:

- Make sure to be the engine speed 1000rpm or less when trawling operation.
- Make sure to be trawling handle position H when normal operation (not trawling operation).

OPTION **KMH4A**

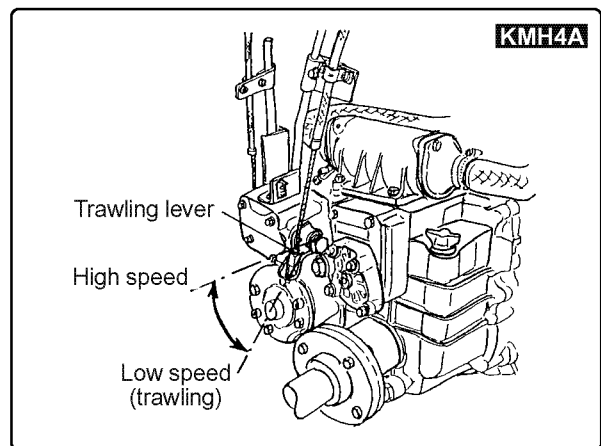
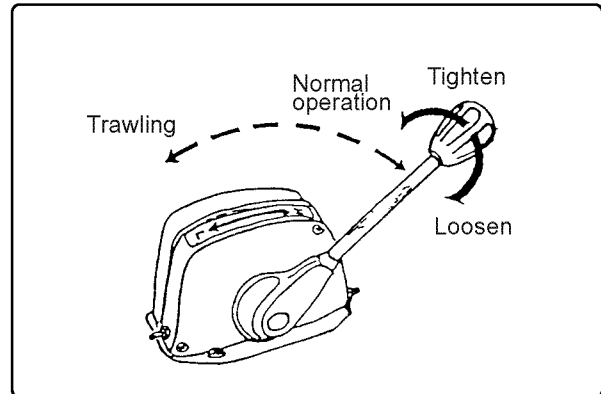

## 3. BEFORE OPERATION

Perform items 3.1 – 3.7 before starting to prepare for operation.

### 3.1 Fuel Oil, Lube Oil and Cooling Water

#### 3.1.1 Fuel Oil

##### (1) Selection of Fuel Oil

Use the following diesel fuels or equivalents.

Select fuels of a higher quality for best engine performance.

- ISO 8217 DMA
- BS 2869 A1 or A2

[Fuels equivalent to Japanese Industrial standard, JIS. No. K2204-2]

Cetane fuel number should be 45 or greater.

##### **NOTICE:**

*When other than the specified fuel oil is used, the engine will not perform to full capacity and parts may be damaged.*

##### (2) Handling of Fuel Oil

- Keep the fuel oil in a clean container. Store the container in a place away from rain and dirt as water and dust mixed in with the fuel cause engine failure.
- Keep the fuel container stationary for several hours to allow any dirt or water to settle to the bottom. Use a pump to extract the clear, filtered fuel from the top of the container for use.

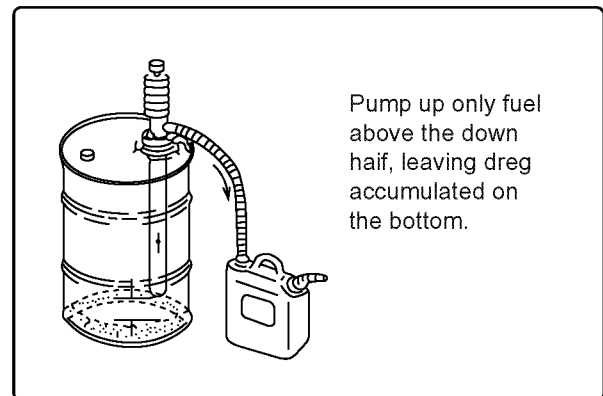

##### (3) Fuel Piping

##### **CUSTOMER**

Install the fuel pipe from the fuel tank to the fuel pump in accordance with the diagram to the right. Be sure to attach a drain cock to the fuel tank to enable dirt and water which have settled at the bottom of the tank to be drained off.

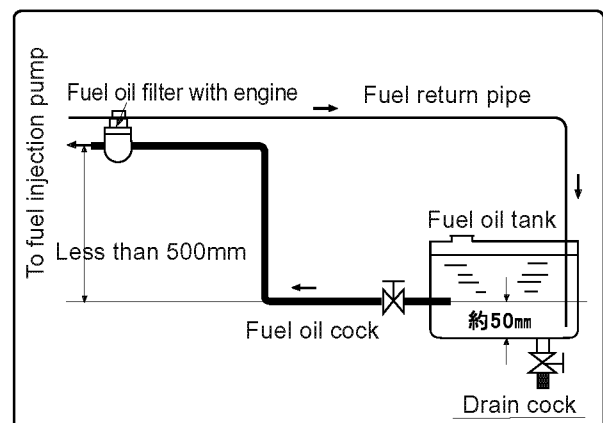

### 3.1.2 Lube oil

#### (1) Selection of Engine Lube Oil

Use the following lube oil:

- \*API Classification CD  
(Standards of America Petroleum Institute)
- \*SAE Viscosity 15W40  
(Standards of Society of Automotive Engineering)

#### **NOTICE:**

*Using other than the specified lube oil will lead to seizure of parts inside the engine and gear device, abnormal wear, and shorten engine life. It will also effect the starting ability and power output.*

#### (2) Marine Gear Oil and sail-drive oil

Be sure to use the following lube oil for the marine gear and the sailing boat drive.

- KBW21  
Converter oil for automobiles ATF
- KM4A, KMH4A  
API Classification ..... CC or higher  
SAE Viscosity ..... #20 or #30(not available multi grade)
- SD40-4T  
Refer to the operation manual for the sail drive.

#### (3) Handling the Lube Oil

- When handling and storing lube oil, be careful not to allow dust and water to enter the lube oil.  
Clean around the filler port before refilling.
- Do not mix lube oils of different types or brands.  
Mixing may reduce the lubricating performance. Different oils are used for the engine and the marine gear.  
Be careful to use the correct oil for each one and store in separate clearly labeled containers.

### 3.1.3 Cooling Water

#### **NOTICE:**

*Be sure to add LLC to cooling fresh water.*

*In cold seasons, the LLC is especially important.*

*Without LLC, cooling performance will decrease due to scale and rust in the cooling water line. Without LLC, cooling water will freeze and expand, breaking various parts.*

- 1) Choose LLC which will not have any adverse effects on the materials (cast iron, aluminum, copper, etc.) of the engine's fresh water cooling system.
- 2) Strictly use the proper mixing ratio of LLC to fresh water as instructed by the LLC maker. If incorrect ratio of LLC to fresh water is used, the cooling performance of the cooling water will drop and the engine may become overheated.
- 3) Do not mix different types (brand) of LLC, chemical reactions may make the LLC useless and engine trouble could result.

#### **NOTICE:**

*Excessive use of LLC also lowers the cooling efficiency of the engine.*

*Be sure to use the mixing ratios specified by the LLC maker for your temperature range.*

## 3.2 Supplying Fuel

### **⚠ DANGER**

#### ***Fires from Oil Ignition***



- *Be sure to use the correct type of fuel when refueling. Mistakenly filling with gasoline or the like will result in ignition.*
- *Be sure to stop the engine before refueling. If you spill fuel, wipe such spillage carefully.*
- *Never place oils or other flammable material close to the engine as this could result in ignition.*

### 3.2.1 Filling the Fuel Tank

Fill the tank with clean fuel which has not been contaminated with water or dust.

Fill the tank to approximately 90% of its capacity, and take care not to let the fuel spill over during operation.

### 3.2.2 Bleeding the Fuel System

Bleed the fuel system according to the following procedure. When there is air in the fuel system, the fuel injection pump will not be able to function.

1. Check the amount of fuel in the fuel tank. If insufficient, replenish.
2. Open the fuel cock of the fuel tank.
3. Loosen the air bleeding bolt on the top of the fuel filter by turning it 2-3 times with a minus driver.
4. Feed the fuel with the priming pump.  
The priming pump is on the top of the fuel filter.  
Move the priming pump knob up and down until fuel mixed with air bubbles flows out of the air bleeding bolt.
5. When the fuel coming out is clear and not mixed with any bubbles, tighten the air bleeding bolt.

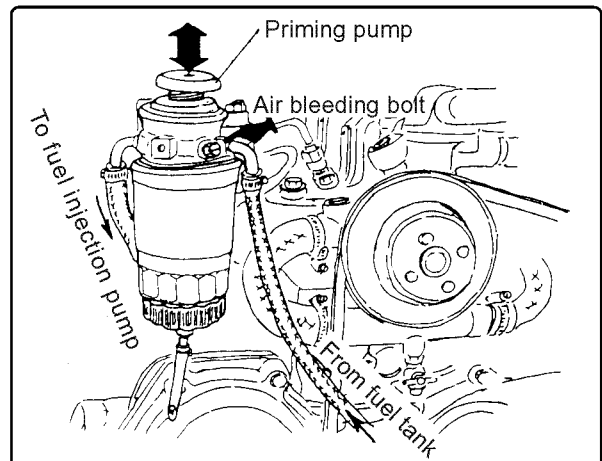



### 3.3 Supplying Engine Lube Oil

Fill with the specified amount of engine oil.

1. Remove the oil inlet cap on the top of the bonnet and fill with oil.
2. Remove the oil dipstick and check the level of the oil with the gauge on the stick.  
Oil should be filled to the upper mark on the dipstick gauge.

**Engine oil capacity:**

**See 2.2 Engine Specifications.**

3. Replace the dipstick and tighten the oil inlet cap firmly by hand.

**NOTICE:**

*Do not overfill.*

*Overfilling will cause oil to be sprayed out from the breather during operation and lead to engine problems.*

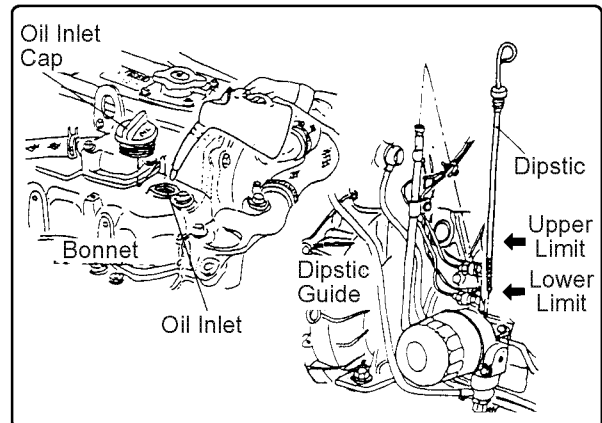

### 3.4 Supplying Marine Gear Lube Oil

Fill with the specified amount of marine gear oil.

1. Remove the oil inlet cap with dipstick on the top of the marine gear and fill with marine gear oil.
2. Fill with oil to the upper mark on the dipstick attached to the cap.  
To measure the oil level, wipe the dipstick using a cloth, and then measure the oil level by inserting the dipstick without tightening screw of the oil inlet cap. Fill with the necessary amount of oil.

**Marine gear oil capacity:**

**See 2.2 Engine Specifications.**

3. Replace the cap and tighten.

**NOTICE:**

*Lower limit is indicated at the end face of the dipstick.*

**NOTICE:**

*Do not overfill.*

*Overfilling will cause oil to be sprayed out during operation and effect the efficiency of the marine gear.*

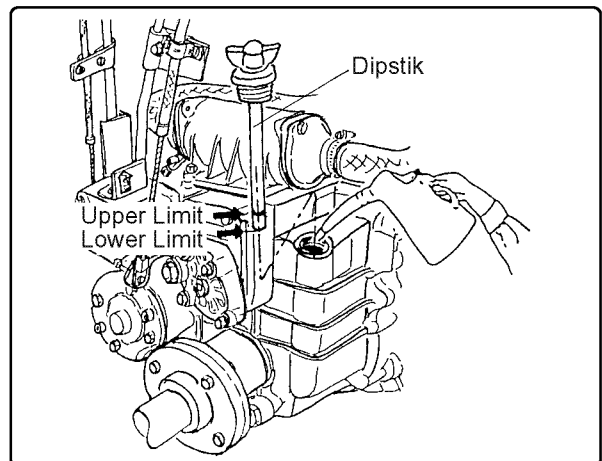

### 3.5 Supplying Cooling Water

**⚠ DANGER**

**Burns from Scalding**



- Never remove the filler cap of the fresh water cooler while the engine is still hot. Steam and hot water will spurt out and seriously bum you. Wait until the water temperature has dropped, then wrap a cloth around the cap and loosen it slowly.
- After inspection, refasten the cap firmly. If the cap is not secure, steam or scalding water may be emitted during operation causing bums.

**Fill the fresh water tank and the subtank with fresh cooling water.**

1. Before filling, check to be sure the drain cocks (indicated in the diagram) are closed.

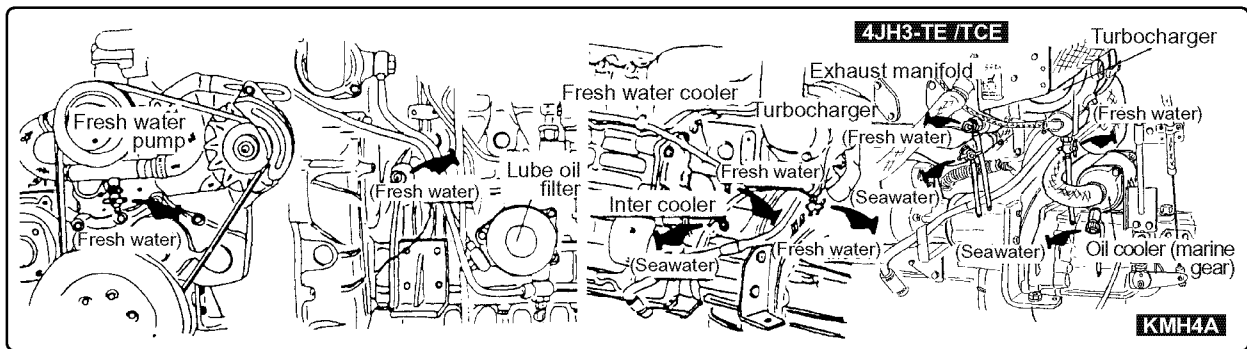

2. Remove the filler cap of the fresh water tank by turning the cap counterclockwise 1/3 of a turn.
3. Pour cooling water slowly into the fresh water tank so that air bubbles do not develop. Supply until the water overflows from the filler port.

**Fresh water tank capacity:**

**See 2.2 Engine Specification**

4. After supplying cooling water, replace filler cap and tighten it firmly. To replace the cap, align the notches on the back of the cap with the slots on the filler port and turn clockwise 1/3 of a turn. (Cont. on next page.)

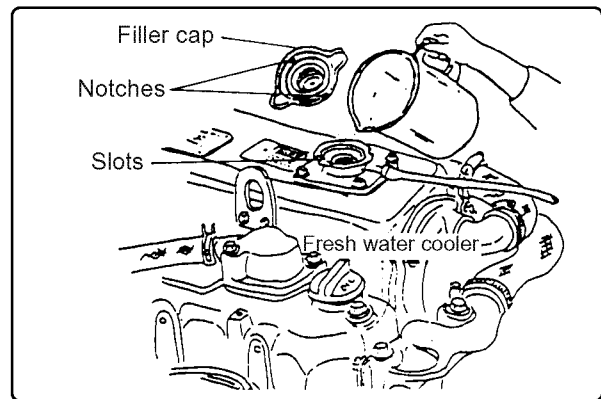

5. Remove the subtank cap and fill with water to the upper limit, **FULL**. Replace cap.

**Subtank capacity:0.8l**

6. Check the rubber hose connecting the subtank to the fresh water cooler. Be sure the hose is securely connected and there is no looseness or damage. If the hose is not watertight, an excessive amount of cooling water will be consumed.

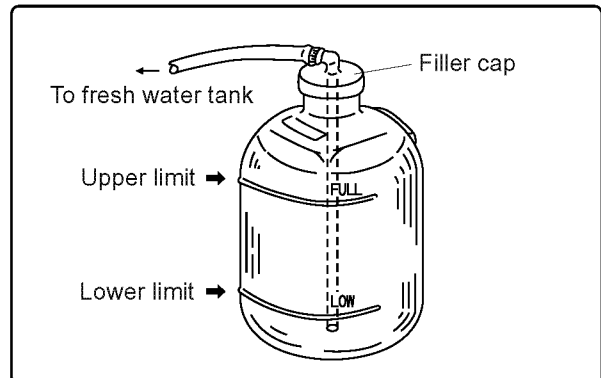

## 3.6 Cranking

When the engine is being used for the first time or if it has not been used for a long period of time, perform cranking before starting to distribute oil to all of the parts. Using an engine which has been stored for a long period of time without the cranking procedure may result in engine seizure, since there will no longer be oil on the moving parts after storage.

1. Open Kingston cock.
2. Cut off all clutches and the main switch, making sure that all auxiliary machines are in a no-load position.
3. Put marine gear in **NEUTRAL**
4. Crank the engine.  
Push the stop button to stop fuel injection while crawling.
  - 1) Put the key into the starter switch.
  - 2) While pushing the stop button, turn the key to the **START** position and hold it there. The engine will begin turning. If you remove your hand from the stop button, the engine will start. Do not take your hand off the button.
5. Continue cranking the engine for about 5 seconds, checking for abnormal sounds.
6. Return the key to the OFF position. The engine will stop.

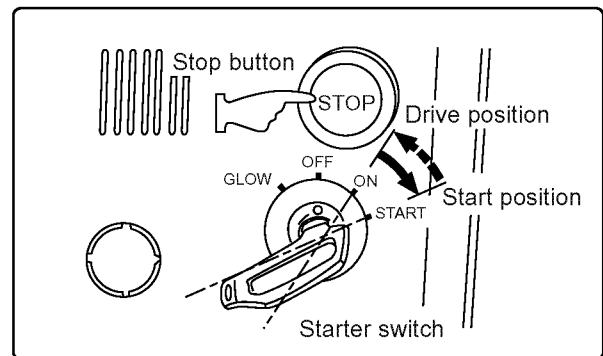
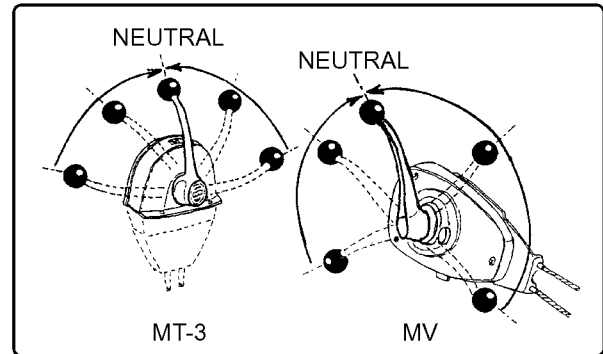

## 3.7 Checking the Lube Oil and Cooling Water

When engine lube oil, marine gear lube oil, and cooling water are put in for the first time, or after they have been replaced, their levels should be checked after a trial operation. Oil and water will be distributed to the various parts during the operation, lowering the levels of oil and water. Replenish to the proper amounts.

- Supplying engine lube oil → See 3.3
- Supplying clutch lube oil → See 3.4
- Supplying cooling water → See 3.5

## 4. HOW TO OPERATE

### ⚠ WARNING

#### Alcohol

- Never operate the engine while you are under the influence of alcohol or when you are ill or feel unwell as this results in accidents.

### ⚠ WARNING



#### Exhaust Gas Poisoning

- Be sure to establish good ventilation in the engine room with windows, vents, or other ventilation equipment. Check again during operation to be sure that ventilation is good. Exhaust gas contains poisonous carbon monoxide and should not be inhaled.

### ⚠ WARNING



#### Moving Parts

- Do not touch the moving parts of the engine (propeller shaft, V-belt, PTO-pulley, etc.) during operation or let your clothing get caught in them as this can result in injury.
- Never operate the engine without the covers on the moving parts.
- Check before starting the engine to see that any tools or cloths used in maintenance have been removed from the area.

### ⚠ CAUTION



#### Burns from Contact with Hot Engine Parts

- The whole engine is hot during operation and immediately after stopping. The turbocharger, exhaust manifold, exhaust pipe, and engine are very hot. Never touch these parts with your body or clothing.

### 4.1 Inspection Before Starting

Be sure to check the following items daily before starting the engine.

#### (1) Visual Check

Check for the following:

If any problem is found, do not use the engine until repairs have been completed.

- Oil leakage from the lube oil system
- water leakage from the cooling water system
- Damage to parts
- Fuel oil leakage from the fuel system
- Loosening or loss of bolts

#### (2) Checking and Resupplying Fuel Oil

Check the fuel level inside the fuel tank and supply with the recommended fuel if necessary.

→See 3.2

#### (3) Checking and Resupplying Engine Lube Oil

1. Check the engine oil level with the oil dipstick.
2. If the oil level is low, supply with the recommended lube oil using the filler port. Supply oil up to the upper mark on the oil dipstick.

→See 3.3

**(4) Checking and Resupplying Marine Gear Oil**

1. Check the marine gear oil level with the dipstick.
2. Supply with the recommended oil if necessary.  
Check the oil level with the dipstick while filling to the upper mark.

→See 3.4

**(5) Checking and Resupplying Cooling Water****⚠ DANGER****Burns from Scalding**

- *Never remove the filler cap of the fresh water tank while the engine is still hot.  
Steam and hot water will spurt out and seriously burn you. Wait until the water temperature has dropped, then wrap a cloth around the cap and loosen it slowly.*
- *After inspection, refasten the filler cap firmly. If the cap is not secure, steam or scalding water may be emitted during operation causing burns.*

1. Check the cooling water level in the subtank.  
If the water level is close to the lower limit, remove the subtank cap and fill with fresh water to the upper limit.
  2. When the water level in the subtank is low, remove the filler cap for the fresh water tank and check the amount of cooling water in the fresh water tank. Fill with fresh water the fresh water tank if the level is low.  
→See 3.5
- Check the fresh water level before operation while the engine is cold.  
Checking the water level while the engine is hot is dangerous, and the cooling water reading will be misleading due to thermal expansion.
  - Check the cooling water daily at the subtank and supply if necessary.  
Do not remove the fresh water tank filler cap regularly.
  - The amount of water in the subtank will increase during operation. This is normal.  
When the engine is stopped, the temperature of the cooling water will drop causing the extra water in the subtank to return to the fresh water tank.

**NOTICE:**

*If the cooling water runs out too often, or if the water level in the fresh water tank falls without any change in the subtank water level, there may be some leakage of water or air. In such cases, consult your Yanmar dealer or distributor without delay.*

**(6) Checking the Remote Control Handle**

*Be sure to check that the remote control handle lever moves smoothly before use. If it is hard to operate, lubricate the joints of the remote control cable and also the lever bearings. If the lever comes out or there is play in the lever, adjust the remote control cable.*

→See 5.2.3(5)

**(7) Preparing Reserves of Fuel, Lube Oil, and Cooling Water**

*Have sufficient fuel ready for the day's operation. In addition, have a reserve of fuel, lube oil, and cooling water (sufficient for at least one refill).*

## 4.2 Checking the Illumination Lamps of the Panel Meters

Be sure to check the alarm devices and other instruments on the panel before and after starting the engine. If the devices are not working properly, it is impossible to prevent any problems arising from insufficient oil and water in the engine. Make checking the alarm and other devices before and after starting a regular practice. If having the optional instrument panel B or C or NewB or NewC, Refer to 2.5.1(2).

### 4.2.1 Checking the Illumination Lamps of the Panel Meters

Turn on the illumination lamp switch of the instrument panel after battery switch and starter key switch turned on and check to see that the illumination lamps come on.

### 4.2.2 Checking the Alarm Devices

#### (1) Check before starting.

1. Turn on the battery switch.
2. Put the key in the starter switch.
3. Turn the key from the **OFF** position to **ON**, and check to see that the alarm devices as shown in the diagram below [Before Starting] are working properly.
  - Buzzer sounds.
  - Charge and engine oil press light up.

#### (2) Check after starting.

When the key returns from the **START** position to **ON**, check to see that the alarm devices as shown in the diagram below [After Starting] are working properly.

- Buzzer stops sounding.
- All of the lamps go off.

Function of Alarm Devices		
Key Operation	Before Starting OFF→ON	After Starting START→ON
Alarm Buzzer	On	Off
Alarm Lamps		
Charge Lamp	On	Off
Cooling Water Temperature	Off	Off
engine Oil pressure	On	Off
Fuel filter	Off	Off
Sail drive leak	Off	Off

By performing these procedures, it can be determined whether or not the electric circuit is in good working order. If there is any problem, consult your yanmar dealer. →See 2.5.1(2)

### 4.2.3 Checking the Panel Meters

**OPTION**

Before starting, the pointer on the meter should be in a fixed position on the left side.

The pointer on the meters will begin moving once the engine is started. Check the position of the pointer to make sure there are no problems.

- Tachometer  
Meter pointer moves to indicate engine speed.
- Cooling Water Temperature Meter  
Meter pointer in the white area is normal. Pointer in the red area indicates a problem.
- Lube Oil pressure Meter  
Meter pointer in the white area is normal. Pointer in the red area indicates a problem.

## 4.3 starting

### 4.3.1 Daily Starting

Follow the following procedures for starting under normal conditions.

1. Open the Kingston cock. (option)
2. Open the fuel tank cock. (option)
3. Cut off all clutches and main switches for all auxiliary machinery so that there is no load.
4. Put the remote control handle in **NEUTRAL**.
5. Set the governor handle in the low speed position (when there is an independent governor remote control handle).
6. Turn on the battery switch. (option)
7. Insert the key into the starter switch and turn it to **ON**, the buzzer sounds and the alarm device lamps come on, indicating that the alarm equipment is working properly.
8. Turn the key to **START** to start the engine. When the engine has started, remove your hand from the key. The key will automatically return to the **ON** position. Check to see that alarm lamps have gone off and the buzzer has stopped. →See 4.2.2

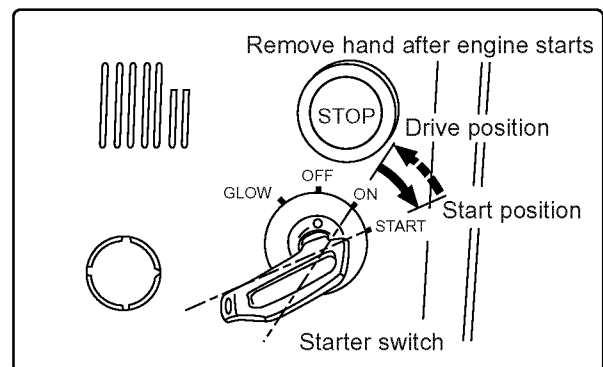
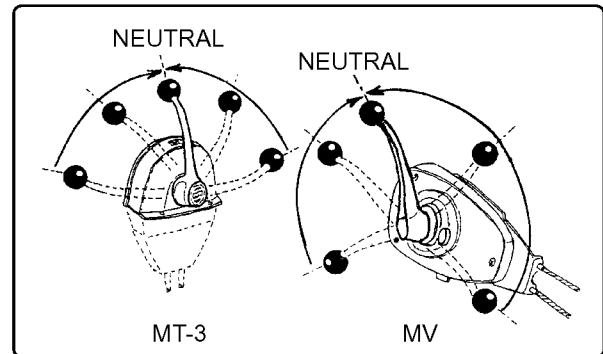

### 4.3.2 Starting Under Low Temperature Conditions

When starting the engine under difficult low temperature conditions (approximately 0 degree C or lower), use the air heater to enable easier starting. Follow steps 1.-6. of the above procedure, and then follow the steps below.

#### OPTION

7. Turn the key from the OFF position to GLOW. Continue to hold the key in the GLOW position to heat up the air heater.
8. Turn the key to **START** and start the engine. After the engine starts, remove your hand from the key.

#### NOTICE:

*Do not leave the air heater on for longer than 20 seconds at a time. Leaving the air heater on for longer periods of time will result in damage.*

### 4.3.3 Restarting After Starting Failure

When attempting to start the engine after starting failure, be sure that the engine is at a complete stop before turning the starter switch key. If the engine is restarted while the engine still has not stopped, the pinion gear of the starter motor will be damaged.

- When the engine will not start after several attempts, check the fuel system. If there is air in the fuel system, the fuel will not be fed and starting will not be possible.

After bleeding air from the system, attempt to restart the engine.

→See 3.2.2

#### NOTICE:

*Do not hold the starter switch on for more than 15 seconds at a time. If the engine does not start the first time, wait for about 15 seconds before trying again.*

### 4.3.4 After the Engine has Started

#### (1) Warming-up running

After the engine has started, let it run for about 5 minutes. This warms up the engine and distributes oil to all of the parts.

#### NOTICE:

*The engine will seize if it is operated when cooling seawater discharge is too small or if load is applied without any warming up operation.*

#### ◆ Morse Remote Control Handle (If having the optional)

1. Leave the remote control handle in **NEUTRAL**.
2. Pull out the handle lever (MT-3) or the free throttle button (MV) and adjust the speed to no more than 1500 rpm and run the engine at low speed with no load.  
→See 2.5.2(4)

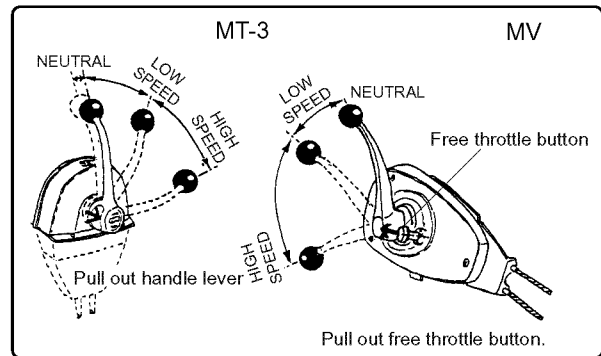

#### (2) Checking for problems

While warming up the engine, check the following items.

1. Check that the meters and alarm devices on the instrument panel are normal.
2. Check for water, fuel and oil leakage from the engine and marine gear.
3. Check that exhaust color, engine vibrations and sound are normal.
4. Check that sufficient cooling water is discharged from the seawater outlet pipe.

Operation with too little seawater discharge will burn the impeller of the seawater pump.

If seawater discharge is too small, stop the engine immediately, identify the cause and repair

- Is the Kingston cock open?
- Is the inlet of the Kingston cock clogged?
- Is the seawater suction hose broken, or does the hose suck in air due to a loose joint?

## 4.4 Adjusting the Engine Speed

Adjust the speed of the engine by moving the remote control handle slowly and smoothly.

Move the handle forward and adjust the speed between **L**(low speed) and **H**(high speed).

◆ For the Morse remote control handle, adjust the engine speed between **NEUTRAL** and **ΔFWD** or **NEUTRAL** and **▽REV**.

#### NOTICE:

*For a new engine be especially careful not to change speeds abruptly or attach a heavy load for the first 50 hours of operation. Doing so will result in damage and shorten the life of the engine.*



## 4.5 Clutch Operation for the Marine Gear

### 4.5.1 Forward, Neutral, Reverse

Use the remote control handle to operate the clutch for the marine gear (FORWARD, NEUTRAL, REVERSE).

- Be sure to run the engine at the lowest possible speed when changing between FORWARD and REVERSE.
- Return the handle to NEUTRAL before moving it to another position. Always move the handle smoothly; never change positions abruptly.
- Be sure to securely position the handle in FORWARD, NEUTRAL, or REVERSE.

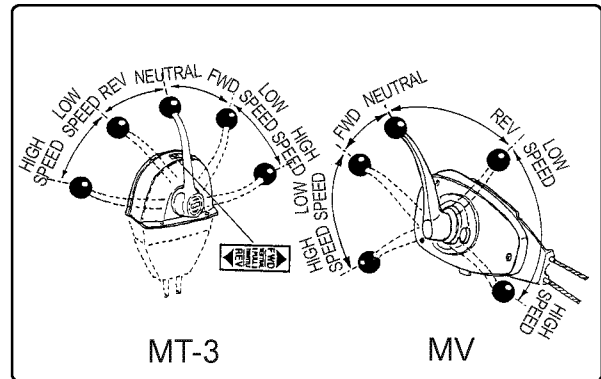

#### NOTICE:

Never operate the clutch when the engine is running at high speed. Doing so will put stress on the engine, driving device, and propeller and result in damage. When shifting the clutch lever, put the engine speed on 1000rpm or less. Additionally, never change speeds abruptly.

#### ◆ Morse Remote Control Handle

- Put the handle in **NEUTRAL** (middle position) to stop the boat. The engine will idle at low speed.
- Move the handle to **ΔFWD** to go forward. When the clutch is engaged in forward, the speed will increase.
- Move the handle to **∇REV** to go in reverse. When the clutch is engaged in reverse, the speed will increase.

### 4.5.2 Switching to Trawling (Available for KMH4A only)

**OPTION KMH4A**

Use the trawling handle to begin trawling. When changing from forward or reverse operation to trawling, the speed of propeller revolution will be reduced to a bare minimum.

#### NOTICE:

When trawling, do not raise the engine speed over 1000rpm, as this results in early wear of and damage to the clutch.

1. Operation continues at a low engine speed of 1000rpm or less.
2. Reduce the speed by moving the trawling handle from H(high speed) to L(low speed).  
Adjust the speed to the desired rate and secure the trawling handle in place.
3. Before returning to normal operation, be sure to put the trawling handle on H(high speed) position.
4. Increase engine speed and continue normal operation.

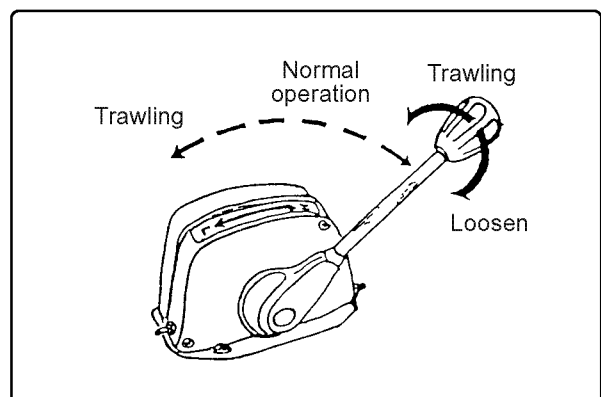

## 4.6 Check During Operation

Always be on the lookout for problems during engine operation.

Pay particular attention to the following.

**(1) Is sufficient water being discharged from the seawater outlet pipe?**

If the discharge is small, stop the engine immediately, identify the cause and repair.

**(2) Is the exhaust color normal?**

The continuous emission of black exhaust shows engine overloading.

This shortens the engine's life and should be avoided.

**(3) Are there abnormal vibrations or noise?**

Do not operate at speeds which produce violent vibrations.

Depending on the hull structure, engine and hull resonance may suddenly become great at a certain engine speed range, causing heavy vibrations. Avoid operation in this speed range.

If you hear any abnormal sounds, stop the engine and inspect.

**(4) Alarm buzzer sounds during operation.**

If the alarm buzzer sounds during operation, lower the engine speed immediately, check the alarm lamps, and stop the engine for repairs.

**(5) Is there water, oil, or gas leakage, or are there any loose bolts?**

Check the engine room periodically for any problems.

**(6) Is there sufficient oil in the fuel tank?**

Replenish fuel oil in advance to avoid running out of fuel during operation.

**(7) When operating the engine at low speed for long periods of time, race the engine once every 2 hours.**

### Racing the Engine

◆ Morse Remote Control Handle

Pull out the handle lever (MT-3) or the free throttle button (MV) and shift the engine speed from high to low several times.

→See 4.3.4(1)

Racing the engine removes carbon built up in the combustion chamber and around the fuel injection valve.

Neglecting to race the engine will cause the exhaust to turn black and lower the efficiency of the engine.

**NOTICE:**

*Never turn off the battery switch or spark the battery cable during operation. Damage to parts in the electric system will result.*

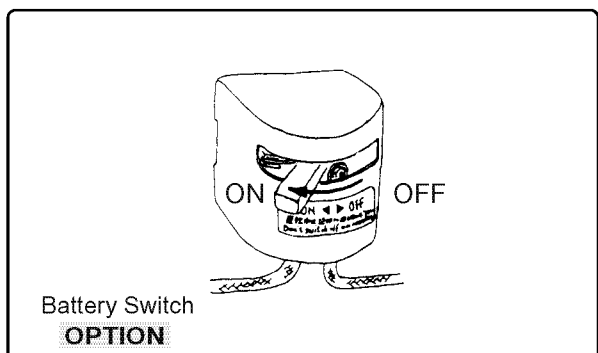
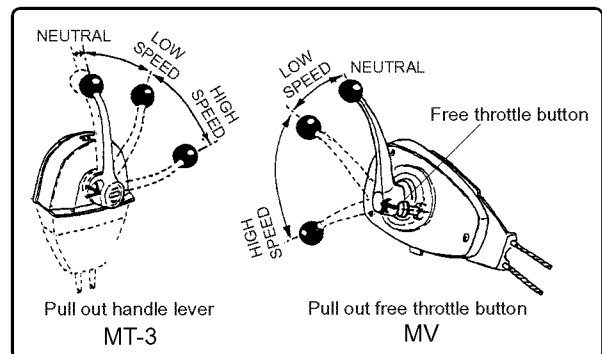

## 4.7 Stopping the Engine

Stop the engine in accordance with the following procedures.

1. Stop the boat.  
Put the remote control handle in **NEUTRAL** and reduce the engine speed to the lowest speed.
2. Be sure to race the engine before stopping it.  
→See 4.6(7)
3. Cool down the engine at low speed (1500rpm or lower) for about 5 minutes.
4. Continue to push the stop button until the engine is completely stopped. If you release the button before the engine has completely stopped, it may restart.
5. Turn the starter switch to OFF, remove the key and place it in a safe place.
6. Cut off the battery switch.
7. Close the fuel tank cock.
8. Close the kingston cock.

In the rare instance where the engine does not stop when the stop button is pushed, stop the engine moving the stop lever attached on the fuel injection pump to the left by hand.

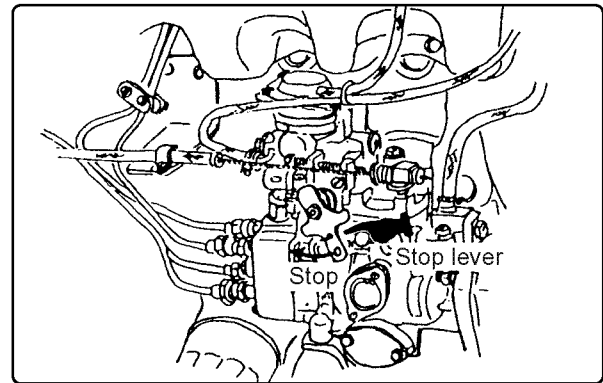
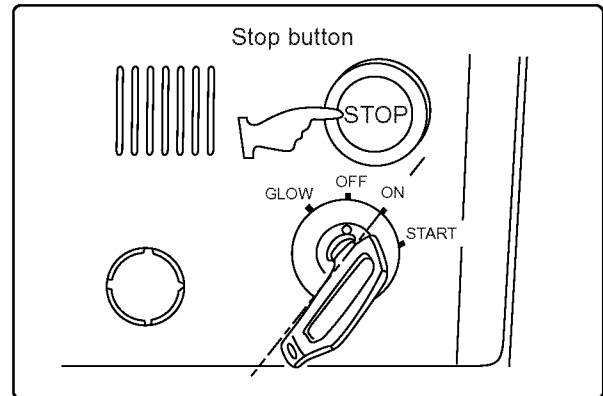

### **NOTICE:**

*Stopping the engine suddenly after operating at high speed or heavy loading without cooling down operation.*

*It will cause the engine temperature to rise quickly resulting in deterioration of the lube oil and sticking of parts.*

### **NOTICE:**

*Neglecting to close the Kingston cock will allow water to leak into the boat and may cause it to sink. Be sure to close the cock.*

## 4.8 Operation Procedure

The following diagram shows the procedures for operation explained up to this point. Parts of the operation may differ depending on the remote control system being used. Accompanying operation manuals should be read carefully and understood.

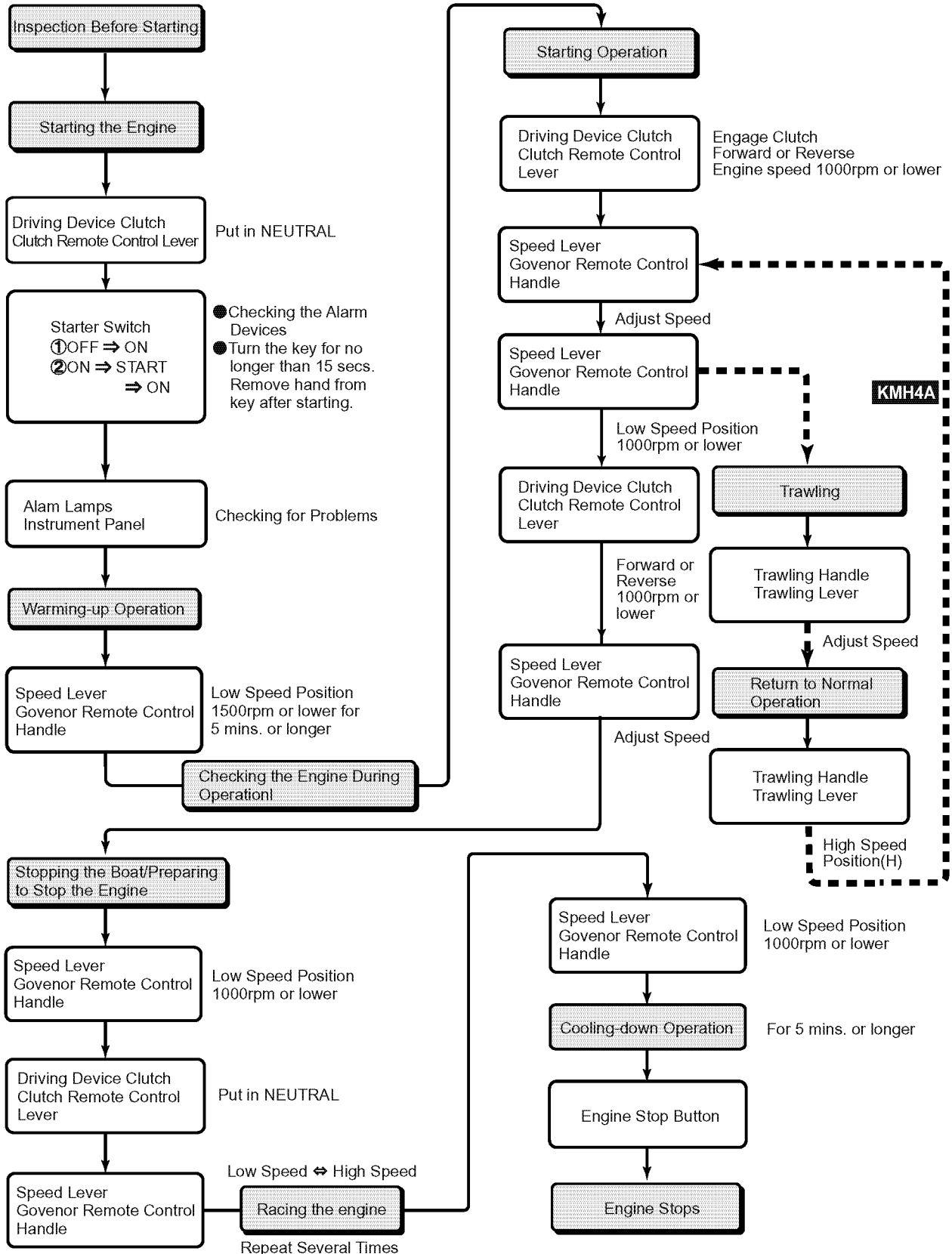

## 4.9 Long-Term Storage

### 4.9.1 Before storing for long periods of time, perform the following.

#### (1) Periodic Inspection

If the time for a periodic inspection is close, perform it before storing the engine for a long period of time.

#### (2) Draining the Cooling Water

When not using antifreeze, be sure to drain the water from the inside of the engine.

#### CAUTION



#### Precautions for Removing Hot Water to Prevent Burns

*Wait until the temperature has dropped before removing cooling water from the engine to avoid getting scalded.*

Drain the water from both the seawater and fresh water systems.

#### NOTICE:

*If the water is not drained, it may freeze and damage parts of the cooling water system.*

#### ◆Draining the water from the seawater system

1. Open the water drain cock on the marine gear oil cooler and drain off the cooling water.  
(The position of the drain cock varies with the different types of marine gears.)
2. Open the water drain cock on the seawater cooling pipe and drain off the cooling water. **4JH3-TE/-TCE**  
Open the water drain cock under the inter cooler and drain off the cooling water. **4JH3-HTE 4JH3-DTE**
3. Loosen the bolts(4) on the side cover of the seawater pump and move the cover to drain off the cooling water inside.
4. After draining off the water, tighten the water drain cocks and replace the side cover on the seawater pump.

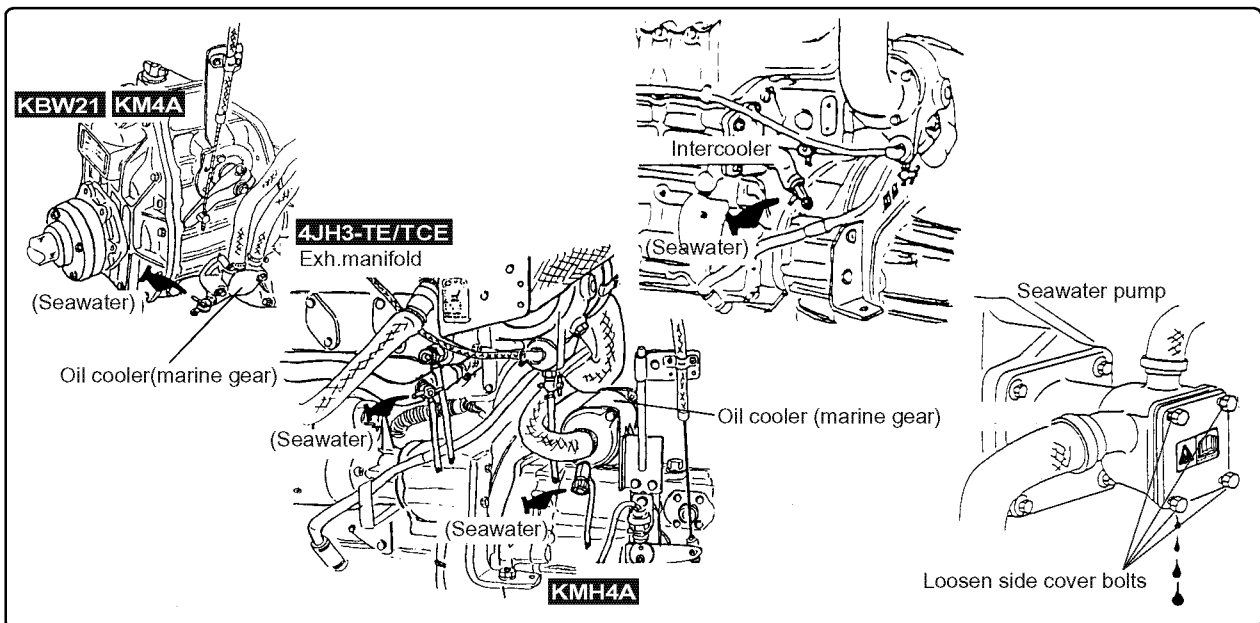

#### ◆Draining the Water From the Fresh Water System

If antifreeze has not been added to the fresh cooling water, be sure to drain the water from the fresh water system in the cold season.

1. Open the fresh water drain cocks at the following 4 positions and drain off the cooling water.

- 1) Side of the cylinder block
- 2) fresh water pump
- 3) turbocharger
- 4) exhaust manifold

**4JH3-TE/TCE**

or fresh water cooler

**4JH3-HTE 4JH3-DTE**

2. Close the drain cocks after draining the water.

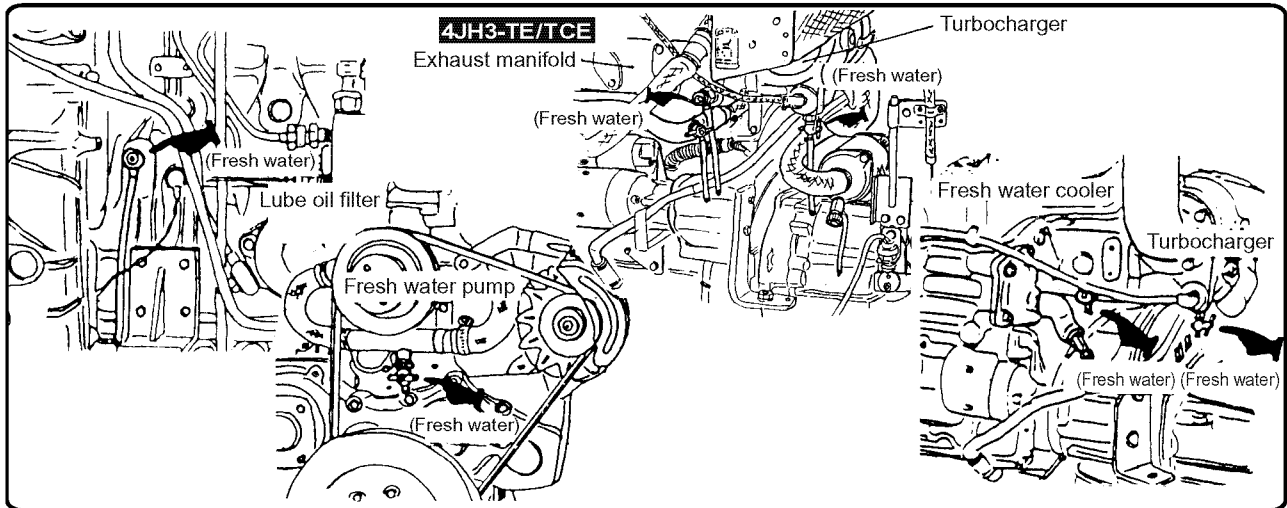

### (3) Cleaning, Draining Fuel Oil, Greasing

- Clean the outside of the engine wiping off any dust or oil.
- To prevent condensation inside the fuel tank, either drain off the fuel or fill the tank.
- Grease the exposed area and joints of the remote control cable and the bearings of the remote control handle.

### (4) Safeguarding the Engine Against Water and Moisture

- Cover the intake silencer, exhaust pipe, etc. with vinyl sheets and seal them to prevent moisture from entering.
- Drain bilge in the hull bottom completely.
- Water may leak into the boat when it is moored, and whenever possible it should be landed.
- Waterproof the engine room to prevent rain and seawater from entering.

### (5) Maintaining the Battery Charge

- Be sure to turn off the battery switch.

During long-term storage, charge the battery once a month to compensate for the battery's self-discharge.

## 4.9.2 Checking the Engine for Reuse After a Long Storage Period

When using the engine after a long period of storage, prepare for operation in the same manner as for a new engine.

→See[3.BEFORE OPERATION]

# 5. MAINTENANCE & INSPECTION

## Conduct Periodic Inspection for Your Safety.

The functions of engine components will degenerate and engine performance will fall according to the use of the engine. If countermeasures are not taken, you may encounter unexpected troubles while cruising at sea. Consumption of fuel or lube oil may become excessive and exhaust gas and engine noise may increase. These all shorten the life of the engine.

Daily and periodic inspection and servicing increase your safety at sea.

## Inspect Before Starting.

Make it a daily rule to inspect before starting.

→See [4.1 Inspection Before Starting]

## Monitor the hour meter and conduct periodic inspections.

Keep a daily record of operation and maintenance. When the time for an inspection approaches, study the relevant pages in the Operation Manual. Inspections should be made after every 50 hrs., 250hrs.(1yr.), 500hrs.(2yrs), 1000hrs.(4yrs.) of use.

## Use Genuine Yanmar Parts.

Be sure to use genuine Yanmar Parts for consumable and replacement parts. Use of other parts will reduce engine performance and shorten the life of the engine.

Specialty technicians are ready to assist you with periodic inspections and maintenance.

Consult your Yanmar dealer or distributor in accordance with the service agreement.

## Always Have Servicing Tools On Hand.

Keep servicing tools close to the machinery and ready for use in inspections.

## Tightening Torque of Bolts & Nuts

It is important to tighten bolts and nuts properly to the correct tightening torque. Over-tightening damages the threads of the bolts and nuts and ruins them. Insufficient tightening causes oil leakage from the installation face or damage to parts. Important parts must be tightened with a torque wrench to the correct tightening torque and in the right order.

Consult with your dealer or distributor if servicing requires the removal of parts.

The standard tightening torque for standard bolts & nuts is listed below.

### NOTICE:

- Apply the following tightening torque to bolts having "7" on the head.  
(JIS strength classification:7T)
- Tighten bolts with no "7" mark to 60% tightening torque.
- If the parts to be tightened are made from aluminum alloy, tighten the bolts to 80% tightening torque.



Bolt dia. × pitch	mm	M6×1.0	M8×12.5	M10×1.5	M12×1.75	M14×1.5	M16×1.5
Tightening torque	N·m (kgf·m)	10.8±1.0 (1.1±0.1)	25.5±2.9 (2.6±0.3)	49.0±4.9 (5.0±0.5)	88.3±9.8 (9.0±1.0)	137±9.8 (14.0±1.0)	226±9.8 (23.0±1.0)

## 5.1 List of Periodic Inspections

Daily and periodic inspection are important to keep the engine in its best condition. The following is a summary of inspection and servicing items by inspection interval. Periodic inspection intervals vary depending on the uses, loads, fuels and lube oils used and handling conditions, and are hard to establish definitively. The following should be treated only as a general standard. Schedule your own periodic inspection plan according to the operational conditions of your engine and inspect every item. Neglecting periodic inspection leads to engine troubles and shortens the life of the engine.

○:Check    ⊗:Replace    ●:Consult local dealer

Item	Content	Daily	Interval term			
			Every 50hrs	Every 250hrs (1 yr.)	Every 500hrs (2 yrs.)	Every 1,000hrs (4 yrs.)
Fuel oil	Check & supply of oil to the tank	○				
	Drain the fuel tank		○			
	Drain the fuel filter		○			
	Replace the fuel filter element			⊗		
Engine Lube oil	Check the quantity of lube oil	○				
	Replace the lube oil		1st time⊗	2nd time & after⊗		
	Replace the lube oil filter element		1st time⊗	2nd time & after⊗		
	Clean the engine oil cooler					●
Marine gear Lube oil	Check the quantity of lube oil	○				
	Replace the lube oil		1st time⊗	2nd time ⊗		3rd time & after⊗
	Wash the lube oil filter		1st time○	2nd time○		3rd time & after○
	Clean the oil cooler					●
Fresh cooling water system	Check & supply of cooling water tank	○				
	Replace the fresh cooling water			⊗		
	Clean & check the cooling water passage					●
Seawater cooling water system	Check the seawater outlet and discharge	○				
	Check & replace the impeller of seawater pump					●
	Clean & check the seawater passage					●
Piping	Check & replace fuel oil pipe, cooling water pipe	○				●
	Replace mixing elbow.	○				●
Electrical equipment	Check the alarm lamps & devices	○				
	Check & supply electrolyte in battery		○			
Belt	Adjusting the V-belt tension			○		
Remote control handle	Check the remote control operation & grease	○				
	Adjusting the remote control cable			○		
Intake and exhaust system	Wash turbocharger blower			○		
	Adjust the intake and exhaust valve clearance				●	
	Lapping the intake and exhaust valve					●
Fuel injection	Check & adjust the fuel injection pressure & atomizing condition				●	
	Check & adjust the fuel injection timing					●



## 5.2 Periodic Inspection Items

### 5.2.1 Inspection After Initial 50Hrs. Operation

#### (1) Replacing the Engine Lube Oil and Lube Oil Filters (1st time)

##### CAUTION



##### Precautions for Removing Hot Oil to Prevent Burns

*If extracting oil from the engine while it is still hot, do not let the oil splash on you.*

During initial operation of the engine, the oil is quickly contaminated due to the initial wear of internal parts. The lube oil must therefore be replaced early. Replace the lube oil filter at the same time.

#### 1. Drain off the lube oil.

It is easier and more effective to drain the engine lube oil while the engine is still warm after operation.

- 1) After removing the oil dipstick, attach the hose of the oil drain pump (optional) to the dipstick guide.
- 2) Drain off the oil with the drain pump.

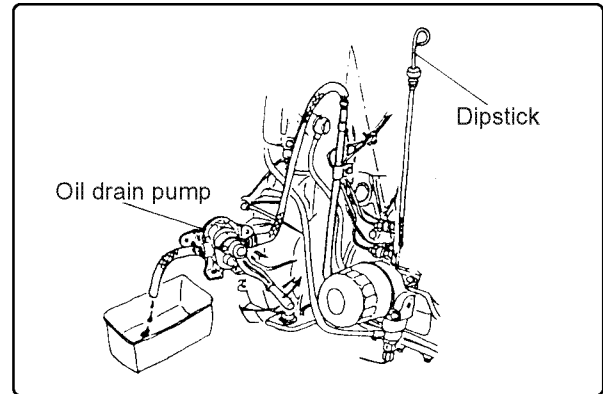

#### 2. Replace the lube oil filter.

- 1) Turn the lube oil filter to the left with the filter wrench and remove.
- 2) Clean the filter installation face.
- 3) Apply engine oil to the installation face and put on the new filter, turning it to the right by hand. Next, tighten an additional 3/4 of a turn with the filter wrench.

[Tightening torque: 19.6~23.5N•m(2.0~2.4kg•m)]

##### Part Number:

**Lube oil filter 129150-35151**

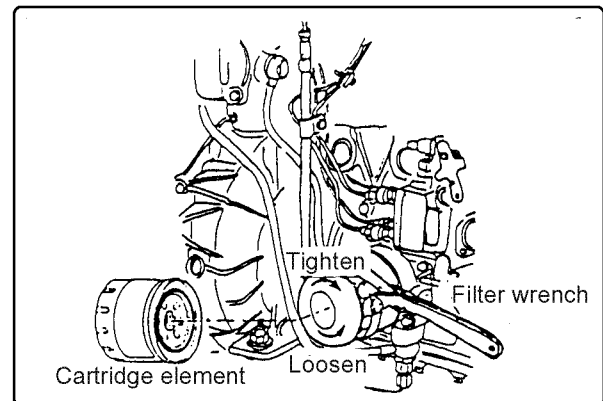

#### 3. Fill with new lube oil.

- 1) Fill with the specified amount of oil.

→See 3.3

- 2) Run the engine for approximately 5 minutes and check to see if there is any oil leakage.
- 3) Approximately 10 minutes after stopping, check the oil level again with the oil dipstick and add more oil if necessary.

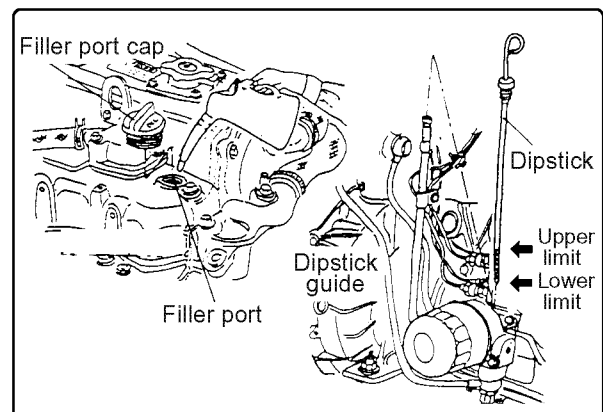

## (2) Replacing the Marine gear Oil and Washing the Oil Filters (1st time)

**CAUTION**

### Precautions for Removing Hot Oil to Prevent Burns

*If extracting oil from the engine while it is still hot, do not let the oil splash on you.*



During initial operation of the marine gear, the oil is quickly contaminated due to the initial wear of internal parts. The lube oil must therefore be replaced early.

**KMH4A** Wash the lube oil filter at the same time.

1. Drain off the marine gear oil.  
it is more efficient to drain the marine gear oil while the marine gear is still warm after operation.

- 1) Remove the filler port cap and insert the hose of the oil drain pump (optional) into the filler port until it reaches the bottom of the marine gear case.
- 2) Drain off the oil using the drain pump.

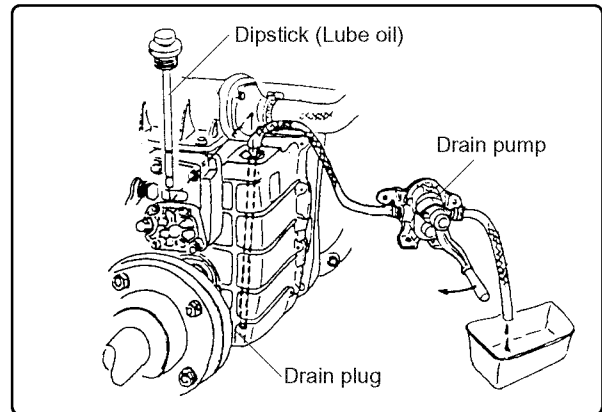

2. Wash the lube oil filter.

- 1) Remove the side cover **KMH4A** and then remove the filter inside the cover.
- 2) Clean the filter thoroughly with kerosene.
- 3) Hold the filter in place with the coil spring and insert and reattach the side cover and screw in the side cover bolt. Insert an O-ring on the filter side of the side cover.

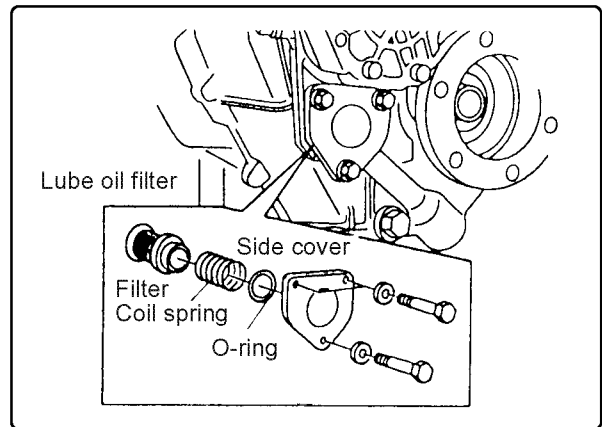

3. Fill with marine gear oil.

- 1) Fill with the specified amount of oil.

→See 3.4

- 2) Run a trial operation to check for oil leakage.

## 5.2.2 Inspection Every 50 Hours

### (1) Draining the Fuel Tank

1. Put a pan under the drain to catch the fuel.
2. Loosen the drain cock at the bottom of the fuel tank, and drain off any water and dirt collected inside.
3. Once the water and dirt have been drained off and the fuel coming out is clear, close the drain plug.

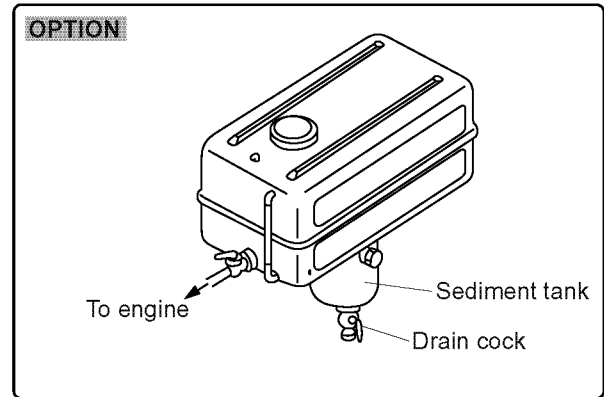

### (2) Drain the fuel filter

When water and dirt are mixed in with the fuel, it becomes impossible for the fuel injection pump and the fuel injection valve to work. Drain periodically to keep the filter from becoming clogged. When there is a lot of drain collected in the oil/water separator, at the bottom of the fuel filter, the fuel filter alarm lamp will light up.

1. Close the fuel cock.
2. Loosen the plug screw at the bottom of the fuel filter oil/water separator, and drain off any water and dirt collected inside.
3. Retighten the plug screw.
4. Be sure to bleed air out of the fuel system.

→ See 3.2.2

When there is a heavy deposit, drain the fuel tank at the same time.

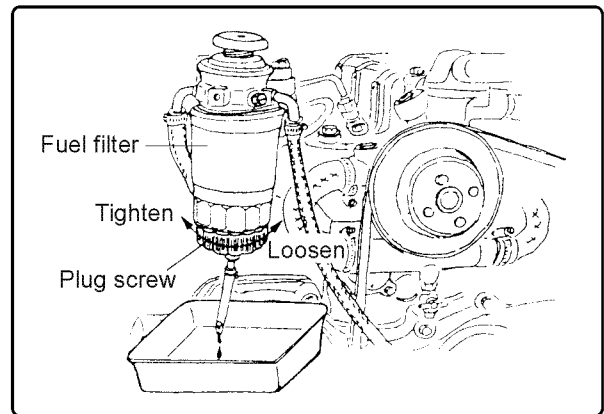

**(3) Inspection of Battery****⚠ WARNING****Fire due to Electric Short-Circuits**

*Always turn off the battery switch or detach the earth cable (-) before inspecting the electrical system. Failure to do so could cause short-circuiting and fires.*

**⚠ DANGER****Proper Ventilation of the Battery Area**

*Be sure the area around the battery is well-ventilated and there is nothing which could start a fire. During operation and charging, hydrogen gas is emitted from the battery and can be easily ignited.*

**⚠ DANGER****Battery Fluid**

*Battery fluid is diluted sulfuric acid. It can blind you if it gets in your eyes, or burn your skin. Keep the fluid away from your body. Wash it off immediately with a large quantity of fresh water if you get any on you.*

- Check the level of fluid in the battery.  
When the amount of fluid nears the lower limit, fill with battery fluid (available in the market) to the upper limit. If operation continues with insufficient battery fluid, the battery life is shortened, and the battery may overheat and explode.
- Battery fluid tends to evaporate more quickly in the summer, and the fluid level should be checked earlier than the specified times.
- If the engine cranking speed is slower than usual rate and the engine difficults to start, recharge the battery.
- If the engine still will not start after charging, replace the battery.

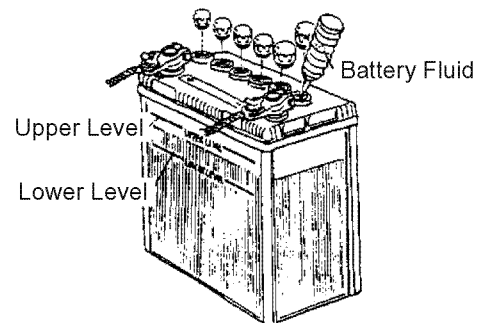
**CUSTOMER**

Follow the instructions and precautions in the manual from the battery maker.

**NOTICE:**

*The capacity of the specified alternator and battery is sufficient for regular operation, however, the capacity may be insufficient if they are used for other purposes such as lights inside the boat, etc. Consult your Yanmar dealer or distributor.*

### 5.2.3 Inspection Every 250 Hrs. or 1 yr.

#### (1) Replacing the Fuel Filter

Replace the fuel filter periodically before there is clogging and the fuel flow is reduced.

1. Close the fuel cock of the fuel tank.
2. Drain the fuel from the fuel drain cock at the bottom of the fuel filter. →See 5.2.2(2)
3. Remove the connectors of the wiring and remove the alarm switch using spanner.
4. Remove the fuel filter using the filter wrench.
5. Clean the fuel filter mounting face.
6. Tighten the new fuel filter  
part No. of the fuel filter:129574-55710
  - Install the alarm switch to the new fuel filter
  - Apply fuel oil to the gasket of the new fuel filter
  - Lightly screw in the fuel filter in position and tighten it by hand until the gasket comes into contact with the seat. After tightening by hand;use the filter wrench to tighten it about 3/4 of a turn  
[Tightening torque:11.8~15.6N·m(1.2~1.6kgf·m)]
7. Bleed the fuel system. →See 3.2.2.
  - If you spill fuel, wipe spillage carefully.
  - Start the engine to check for fuel leakage.

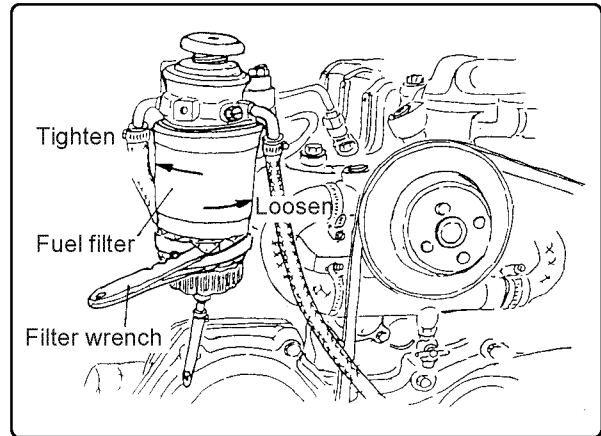

#### (2) Replacing Cooling Water

Cooling performance drops when the cooling water is contaminated with rust and scale.

Even if antifreeze is added, the cooling water must be periodically replaced because the properties of the agent will degenerate. Replace the cooling water periodically.

- Draining the Cooling Water →See 4.9.1(2).
- Supplying Cooling Water →See 3.5

#### (3) Replacing the Engine Oil and Lube Oil Filter (2nd time & after)

After the second oil change, the engine oil should be replaced after every 250 hours.

Replace the lube oil filter at the same time. →See 5.2.1(1)

**(4) Replacing the Marine Gear Oil and Washing the Oil Filter (2nd time)**

Replace the marine gear oil for the 2nd time.

Wash the filter at the same time. →See 5.2.1(2)

**KMH4A****(5) Adjusting the Remote Control Handle**

The remote control handles and the engine speed control lever and clutch shifting lever are connected by an remote-control cable. Over time the cable becomes stretched and the connections loose causing deviation in the position which makes operation unsafe. Inspect the wire periodically and adjust if necessary.

**(5A) Adjusting the Governor Remote Control Handle**

1. Check to see that the speed control lever on the engine side is touching the high speed limiting bolt(high idle) when the governor handle is put in H(High Speed) position.
2. Check to see that the speed control lever on the engine side is touching the low speed limiting bolt(low idle) when the governor handle is put in L(Low Speed) position.
3. If the speed control lever does not touch the limiting bolt for either the high or low speed when you check them, loosen the setting screws on the fittings for the accelerator cable and adjust the position of the cable.

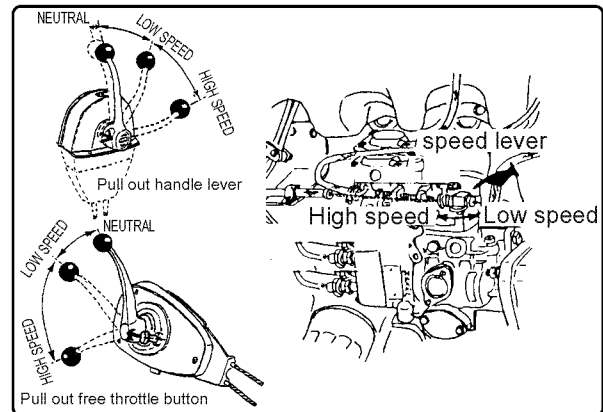
**NOTICE:**

*Never remove the limiting bolt for the fuel injection pump or the restraint bolt on the amount of fuel injected. Doing so will impair safe operation and lower the efficiency of the engine and shorten its life.*

**(5B) Adjusting the Clutch Remote Control Handle for the Marine Gear**

1. Check to see that the clutch lever on the marine gear side is in the neutral position when the remote control handle is in NEUTRAL.
2. If the position of the clutch lever is incorrect, loosen the setting screw of the cable fitting and adjust the position of the cable.
3. Check the clutch lever in  
 $\Delta$ FWD(Forward)  
 $\nabla$ REV(Reverse)  
 making sure it is correctly aligned.
4. Make any necessary adjustments using NEUTRAL as the base position.

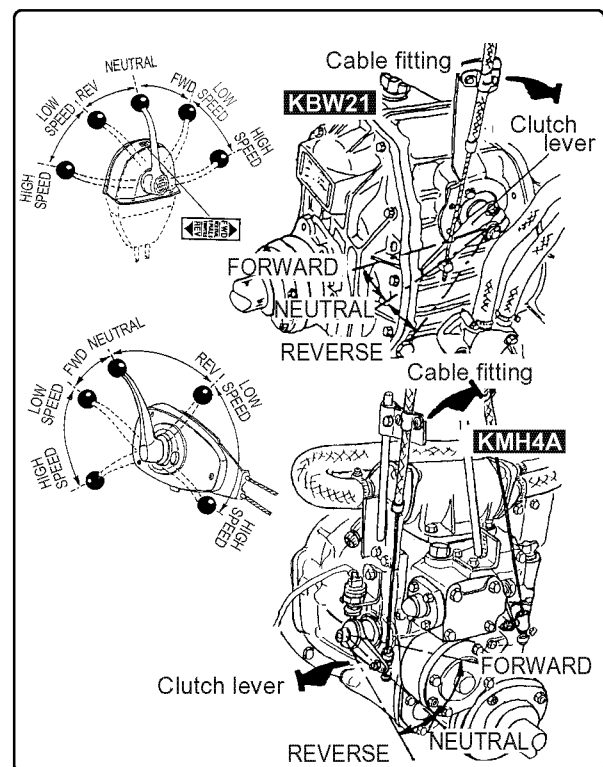

**(5C) Adjusting the Position of the Trawling Remote Control Handle****OPTION KMH4A**

1. Check to see that the trawling lever on the marine gear side is in the high speed position when the trawling remote control handle is in H(high speed) position.
2. Check to see that the trawling lever on the marine gear side is in the low speed position when the trawling remote control handle is in L(low speed) position.
3. If the positions are not aligned, loosen the setting screw of the cable fitting and adjust the position of the cable.

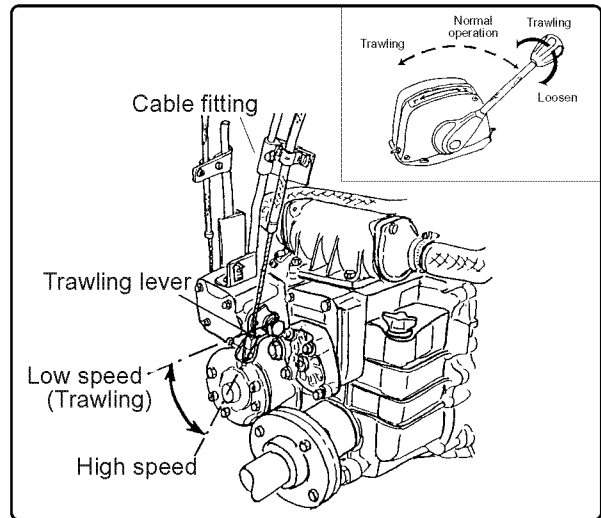
**(6) Washing the Turbocharger Blower**

When engine speed seems sluggish or the exhaust color poor, the blades of the turbocharger blower may be dirty. Wash the blower in the following manner.

1. Have ready blower wash (liquid detergent), fresh water, and a small pitcher.

**Blower Wash (4L)****Parts Code:974500-00400**

2. Put the clutch in neutral and run the engine at high speed (2500~3000rpm).
3. Slowly pour approximately 50cc of blower wash into the turbocharger air intake over a period of about 10 seconds.
4. After about 3 minutes, pour in approximately 50cc of fresh water in the same manner over a period of about 10 seconds.
5. After operating the engine for about 10 minutes, check the boost pressure and power output. If there is no improvement after washing the blower, repeat the washing process several times. If there is still no improvement consult your local Yanmar dealer.

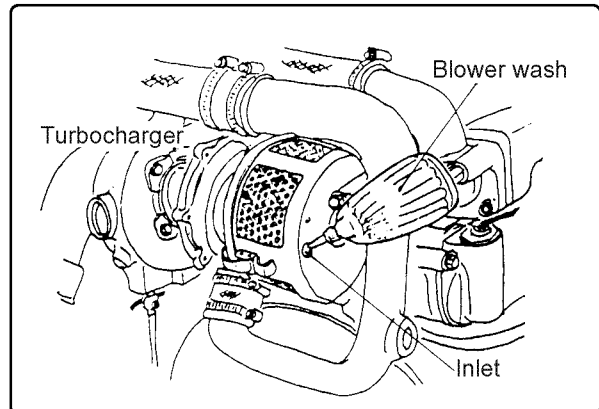
**NOTICE:**

*Do not pour in a large amount of blower wash at one time (pour it in gradually) as this can damage the blower blades and get water hammer in the combustion chamber leading to accidents.*

**(7) Checking the Tension of the V-Belt of the Alternator**

When there is not enough tension in the V-belt, the belt will slip making it impossible for the alternator to generate power.

Additionally, the fresh water pump will not work causing the engine to overheat.

Check the tension of the V-belt in the following manner.

1. Press the V-belt down with your thumb at the middle of the belt to check the tension.

The give in the V-belt should measure about 8~10mm at the depression.

2. To adjust the V-belt tension, loosen the set bolt and move the alternator.

3. Replace the belt if it is damaged.

**Parts No: 25132-004600(A-46)**

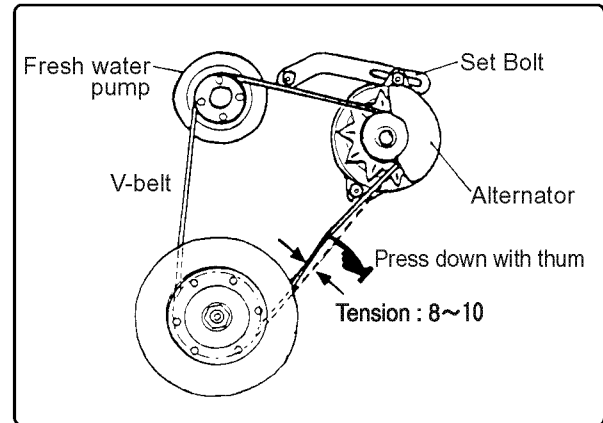
**NOTICE:**

- If the V-belt tension is too tight, the belt and the bearings of the alternator will be damaged.
- Be careful not to spill any oil on the V-belt as this will lead to stretching and slippage.

**5.2.4 Inspection Every 500 Hrs. or 2 yrs.****(1) Adjustment of Intake/Exhaust Valve clearance**

This maintenance requires specialized knowledge. Consult your Yanmar dealer or distributor. Adjustment is necessary to maintain the correct timing for the opening and closing of valves. Neglecting adjustment will cause the engine to run noisily and result in reduced power output and other damage.

**(2) Inspecting and Adjusting Fuel Injection Valves**

This maintenance requires specialized knowledge. Consult your Yanmar dealer or distributor. Fuel injection must be adjusted to ensure optimal engine performance.



## 5.2.5 Inspection Every 1000 Hrs. or 4 yrs.

### (1) Replacing the Marine gear Oil and Washing the Lube Oil Filter

(3rd time and thereafter)

Replace the marine gear oil for the 3rd time after 1000 hrs.

At the same time, wash the filter at the marine gear entrance. →See 5.2.1(2)

**KMH4A**

### (2) Inspecting Inner Parts of the Seawater Pump

The inside parts of the seawater pump will deteriorate with use, and discharge performance falls. At the specified interval or when the volume of seawater discharged is reduced, inspect the seawater pump in accordance with the following procedures.

→See 4.9.1(2)

1. Loosen the side cover set bolts (4) and remove the side cover.
2. Illuminate the inside of the seawater pump with a flashlight and inspect. If any of the following problems is found, disassembly and maintenance are necessary.
  - Impeller blades are cracked or nicked.  
Edges or surfaces of the blades are marred or worn.  
The impeller must be replaced periodically every 2000 hrs.
  - Wear plate is damaged.
3. If no damage is found when inspecting the inside of the pump, replace the side cover. Fit the O-ring to the groove of the joint face before replacing the side cover.

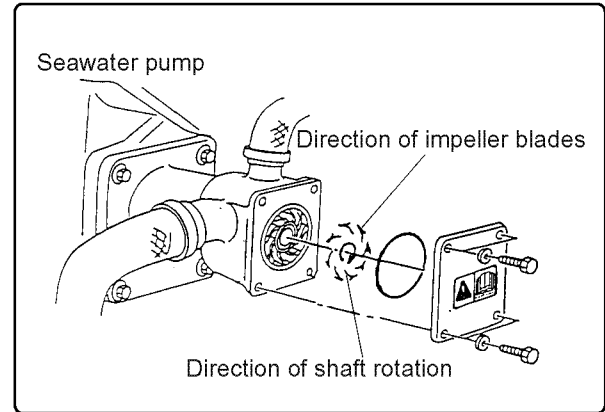

#### **NOTICE:**

- When the impeller has been disassembled, be careful to replace it so that it moves in the correct direction. The seawater pump turns clockwise, but the impeller blades must be installed in the counterclockwise direction.
- When turning the engine by hand, be sure to turn it in the correct direction. Turning it in the opposite direction damages the blades of the impeller.

If water leaks continuously from the seawater pump during operation disassembly and maintenance (replacement of the mechanical seal) are necessary.

When disassembly and maintenance of the seawater pump are necessary, consult your Yanmar dealer or distributor.

### (3) Washing the Cooling Water System and Checking and Maintaining Parts

This maintenance requires specialized knowledge. Consult your Yanmar dealer or distributor.

Over time rust and scale builds up in the seawater and fresh water systems reducing their cooling performance. Additionally, when the inside of the engine oil cooler and the marine gear oil cooler become dirty, lube oil cooling worsens causing the oil to deteriorate more quickly.

Wash the following related parts when the cooling water is being replaced.

Cooling water system related parts: seawater pump, engine oil cooler, marine gear oil cooler, fresh water pump, fresh water cooler, thermostat, etc.

**(4) Checking and Replacing the fuel pipe and the cooling water pipe**

This maintenance requires specialized knowledge. Consult your Yanmar dealer or distributor. Check the hoses of the fuel and cooling water pipings and replace if damaged.

**(5) Replacing the Mixing Elbow**

This maintenance requires specialized knowledge. Consult your Yanmar dealer or distributor. The mixing elbow which is constantly in contact with exhaust gas and seawater deteriorates with use and must be replaced. If operation is continued without replacing faulty elbow, water will leak into the boat, and gas leakage may result in fires.

**(6) Lapping of Intake/Exhaust Valves**

This maintenance requires specialized knowledge. Consult your Yanmar dealer or distributor. Adjustment is necessary to maintain proper contact of the valves and seats.

**(7) Checking and Adjusting the Fuel Injection Timing**

This maintenance requires specialized knowledge. Consult your Yanmar dealer or distributor. Fuel injection timing must be adjusted to ensure optimal engine performance.

# 6. TROUBLE AND TROUBLESHOOTING

## 6.1 Simple problems and the appropriate countermeasures

If you should encounter some difficulty during operation, refer to the following table for countermeasures.

Trouble	Probable Cause	Measure	Reference
Problem occurs during operation. ◆ Alarm buzzer sounds and alarm lamps come on.	<b>NOTICE:</b> When the alarm equipment indicates a problem, immediately put the clutch in neutral and run the engine at low speed. Check to see which alarm indicator is lit, then stop the engine and inspect. When you cannot determine the source of the problem, return to port at low speed and ask your Yanmar dealer for repairs.		
Charge Lamp (Alarm buzzer does not sound.)	Faulty battery V-belt is loose or damaged Alternator is not generating electricity	Check battery fluid. Adjust V-belt tension or replace belt. Ask for repairs.	5.2.2(3) 5.2.3(7)
C.W. Temp. Lamp goes on.	Insufficient cooling water in fresh water tank Leakage in fresh water cooling system Fresh water cooling pump is damage Inside of C.W. system is dirty.	Check and replenish cooling water. Ask for repairs for water leakage Ask for repairs. Ask for repairs.	3.5
L.O. Press. Alarm Lamp goes on.	Insufficient engine oil	Replenish engine oil.	3.3
Fuel Filter Alarm Lamp goes on.	Increased fuel filter drain	Drain the fuel filter.	5.2.2(2)
Fuel Oil Alarm Lamp goes on.	Insufficient fuel oil	Replenish fuel oil.	3.2
Faulty Alarm Devices	<b>NOTICE:</b> Do not operate the engine if alarm devices are not working properly. Serious accidents may result if difficulties are not spotted due to faulty alarm lamps.		
◆ Before starting when switch is turned from OFF→ON, alarm devices do not work.			4.2.2
Alarm buzzer does not sound.	Circuit broken or buzzer damaged	Ask for repairs.	-
Some alarm lamps do not light up.	Circuit broken or lamp burnt out.	Ask for repairs.	-
◆ After starting when switch is turned from START→ON, alarm devices do not work.			4.2.2
Alarm buzzer does not stop	Short circuit	Ask for repairs.	-
Some alarm lamps do not go off	Damaged sensor or switch	Ask for repairs.	-

Trouble	Probable Cause	Measure	Reference
Starting Failures			
Starter works. but engine does not start.	No fuel Air in fuel line Bad fuel	Replenish fuel; bleed. Bleed. Replace with recommended fuel.	3.2 3.2.2 3.1.1
	Clogged fuel filter Poor fuel injection Pressure leakage from intake/exhaust valves	Replace fuel filter. Ask for repairs. Ask for repairs.	5.2.3(1)
Starter does not turn or turns too slowly (Can be turned by hand)	Insufficient battery charge Faulty cable connection at terminal Faulty starter switch Faulty clutch safety switch Faulty starter	Check battery fluid, recharge. Remove rust from terminal; retighten Ask for repairs. Ask for repairs. Ask for repairs.	5.2.2(3)
Cannot be turned manually.	Inner parts seized or damaged	Ask for repairs.	-
◆ Poor exhaust color			
Black smoke emitted.	Overload Improper fuel Boost pressure low Faulty spraying of F.O. injection Excessive intake/exhaust valve clearance	Reduce load. Replace with recommended fuel. Wash turbocharger blower. Ask for repairs. Ask for repairs.	3.1.1 5.2.3(5)
White smoke emitted.	Improper fuel Faulty spraying of F.O. injection Fuel injection timing delay Lube oil burns/excessive consumption	Replace with recommended fuel. Ask for repairs. Ask for repairs. Ask for repairs.	3.1.1
◆ Faulty Clutch Action			
Remote control handle action is heavy	Rusty cable	Grease the cable or replace.	-
Propeller shaft revolves when in NEUTRAL	Clutch lever is incorrectly aligned. Propeller shaft incorrectly installed.	Adjust the position of the clutch lever. Ask for repairs.	5.2.3(5B)
Propeller shaft does not revolve when in FORWARD or REVERSE. Or, revolves with insufficient speed	Operating at high speed while trawling position. Insufficient clutch oil. Broken oil pump. Worn clutch friction plate.	Change the trawling lever to H position Refill with clutch oil. Ask for repairs. Ask for repairs.	2.5.2(2) 3.4
When the clutch is broken and the boat will not move, see.[6.2 Emergency Repairs for Marine gear trouble].			

## 6.2 Emergency Repairs for Marine Gear Trouble

If the marine gear should break, the boat will not run. In case of this emergency, follow the following procedure for using the clutch emergency bolt to return to port.

Note: Cannot be used for KBW21 and KM4A marine gear.

### NOTICE:

- Using the emergency bolt directly connects the clutch of the marine gear to the engine making it possible to turn the propeller. However, when the engine is started and the propeller turns, the boat will only move forward. The neutral and reverse positions cannot be used.

The emergency bolt should only be used in cases where it is impossible to operate the clutch and the boat must return to port. Ask your Yanmar dealer for repairs immediately after returning to port.

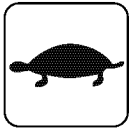

- When using the emergency bolt, never use the clutch as this will break it.
  - Operate at low speed, 1000rpm or less, and navigate carefully.
- When approaching the pier, turn off the engine early and stop the boat.

Perform the following after turning off the engine.

1. Remove the hexagonal red bolts at the back of the marine gear with a spanner.

2. Check to see if the emergency bolt is visible at the back of the bolt hole.

When the emergency bolt is not visible, insert a turning stick little by little in the holes at the front side of the V-pulley, turning it in the direction of the crank shaft rotation and stopping when the emergency bolt becomes visible.

3. Inset the emergency bolt tightening tool into the bolt hole and tighten the emergency bolt.

4. There are 2 emergency bolts.

Follow the procedure described in 2. and 3. for the second bolt, and tighten the bolts alternately applying the same amount of force to each.

Tightening torque:  $18.6 \pm 1.0 \text{ N} \cdot \text{m}$  ( $1.9 \pm 0.1 \text{ kgf} \cdot \text{m}$ )

5. Replace the hexagonal bolt.

6. Fill with the marine gear oil set aside for emergencies to the mouth of the filler port. (When the oil pump is not working, there is no lubrication and filling with oil is essential.)

7. Start the engine with the clutch handle in neutral and proceed at low speed.

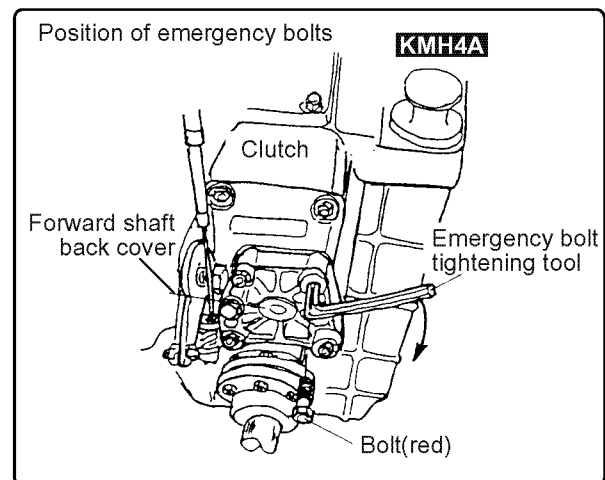
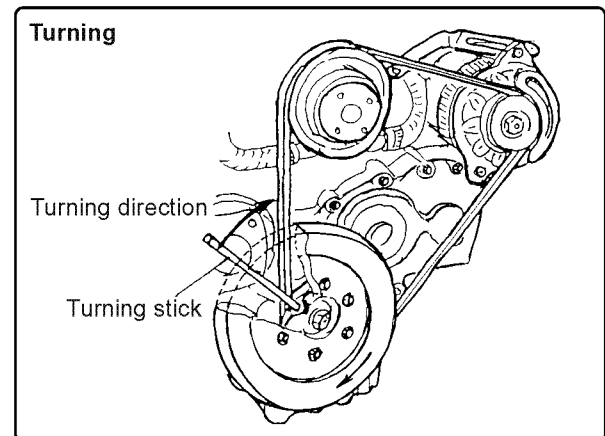

## 6.3 Consulting Your Yanmar Dealer or Distributor

Refer difficult problems and repairs to your Yanmar dealer or distributor.

At the time of trouble, check and report the following.

1. Engine model and number [For engine name plate, see 2.3(Names of Parts).]
2. Boat name, hull material, boat size (tons)
3. Use, type of work, no. of hours run
4. Total no. of operation hours (refer to hour meter), ago of machine  
If there is no hour meter, use number of hours per day×number of days and amount of fuel used.
5. Condition immediately before trouble (engine rpm, type of operation, load condition, etc.)
6. Details of trouble  
(exhaust color, sound of engine, does engine start, can engine be turned manually, type of fuel used, brand and viscosity of lube oil, etc.)
7. Past problems and repairs.

## Warranty Service

### Owner Satisfaction

Your satisfaction and good will are important to your dealer and to us.

Normally, any problems concerning the product will be handled by our dealer's service department.

If you have a warranty problem that has not been handled to your satisfaction, we suggest you take the following action:

- Discuss your problem with a member of dealership management. Often complaints can be quickly resolved at that level. If the problem has already been reviewed with the Service Manager, contact the owner of the dealership or the General Manager.
- If your problem still has not been resolved to your satisfaction, contact your Yanmar local Subsidiary Company. (See the back cover of this manual)

We will need the following information in order to assist you:

- Your name, address and telephone number
- Product model and serial number
- Date of purchase
- Dealer name and address
- Nature of problem

After reviewing all the facts involved, you will be advised of what action can be taken.

Please bear in mind that your problem will likely be resolved at the dealership, using the dealer's facilities, equipment and personnel, so it is very important that your initial contact be with the dealer.

MEMO

# 7. SYSTEM DIAGRAM

## 7.1 Wiring diagram

### 7.1.1 B type Instrument Panel (Optional) 1/2 (Panel side)

Starter switch

	30	AC	17	G1	G2
GLOW	○			○	
OFF	○				
ON	○	○			
START	○		○		○

Color coding

R	Red
B	Black
W	White
L	Blue
RB	Red/Black
LB	Blue/Black
YW	Yellow/White
YB	Yellow/Black
YG	Yellow/Green
WL	White/Blue
WB	White/Black
WR (RW)	White/Red (Red/White)
WG (GW)	White/Green (Green/White)
GB	Green/Black
YR	Yellow/Red
GR (RG)	Green/Red (Red/Green)
O	Orange
BrW	Brown/White
WBr	White/Brown
LW	Blue/White
Y	Yellow

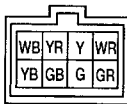
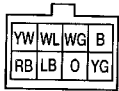

Detail of coupler AA

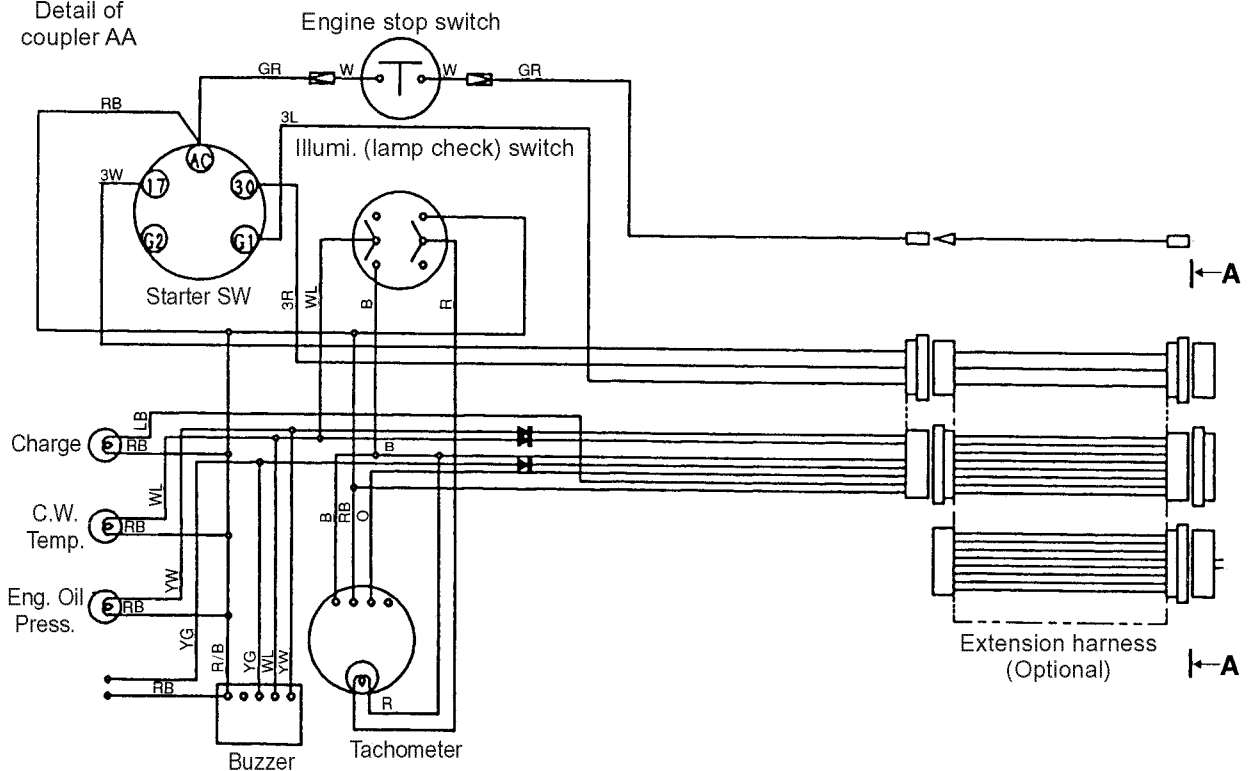



2/2 (Engine side)

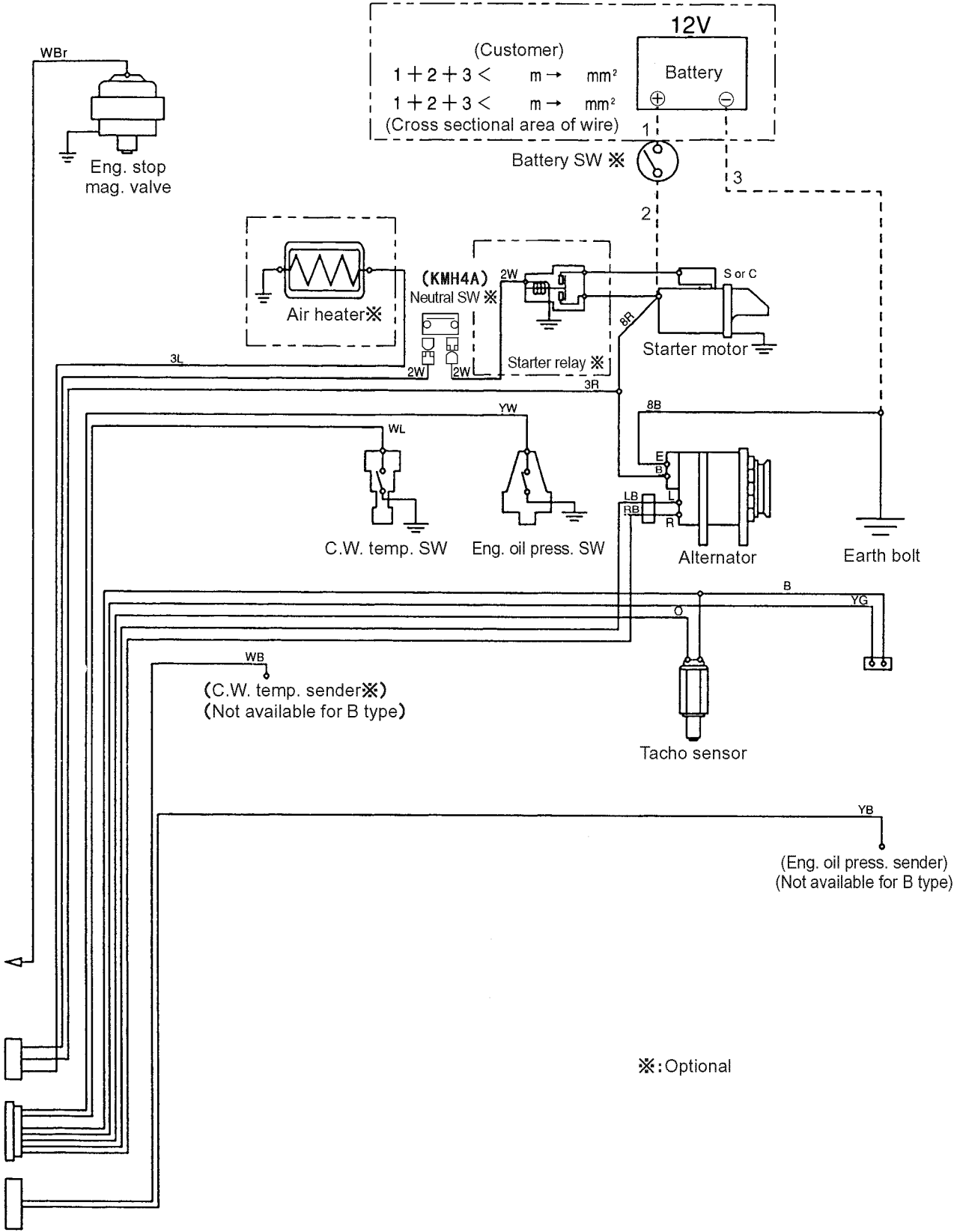

### 7.1.2 C type / C type × B type(No.2 station) Instrument Panel (Optional) 1/2 (Panel side)

Starter switch

	30	AC	17	G1	G2
GLOW	○			○	
OFF	○				
ON	○	○			
START	○		○		○

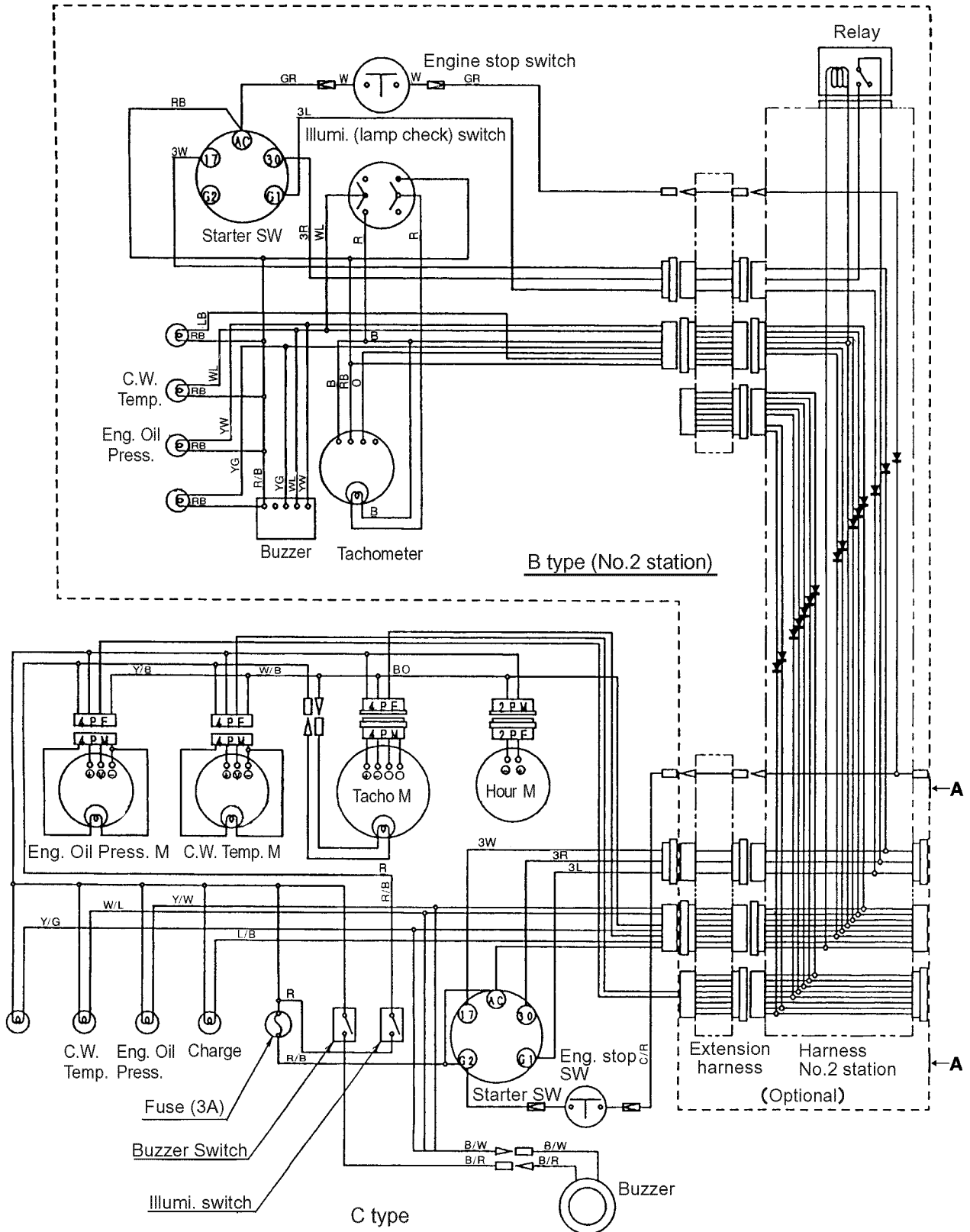

2/2 (Engine side)

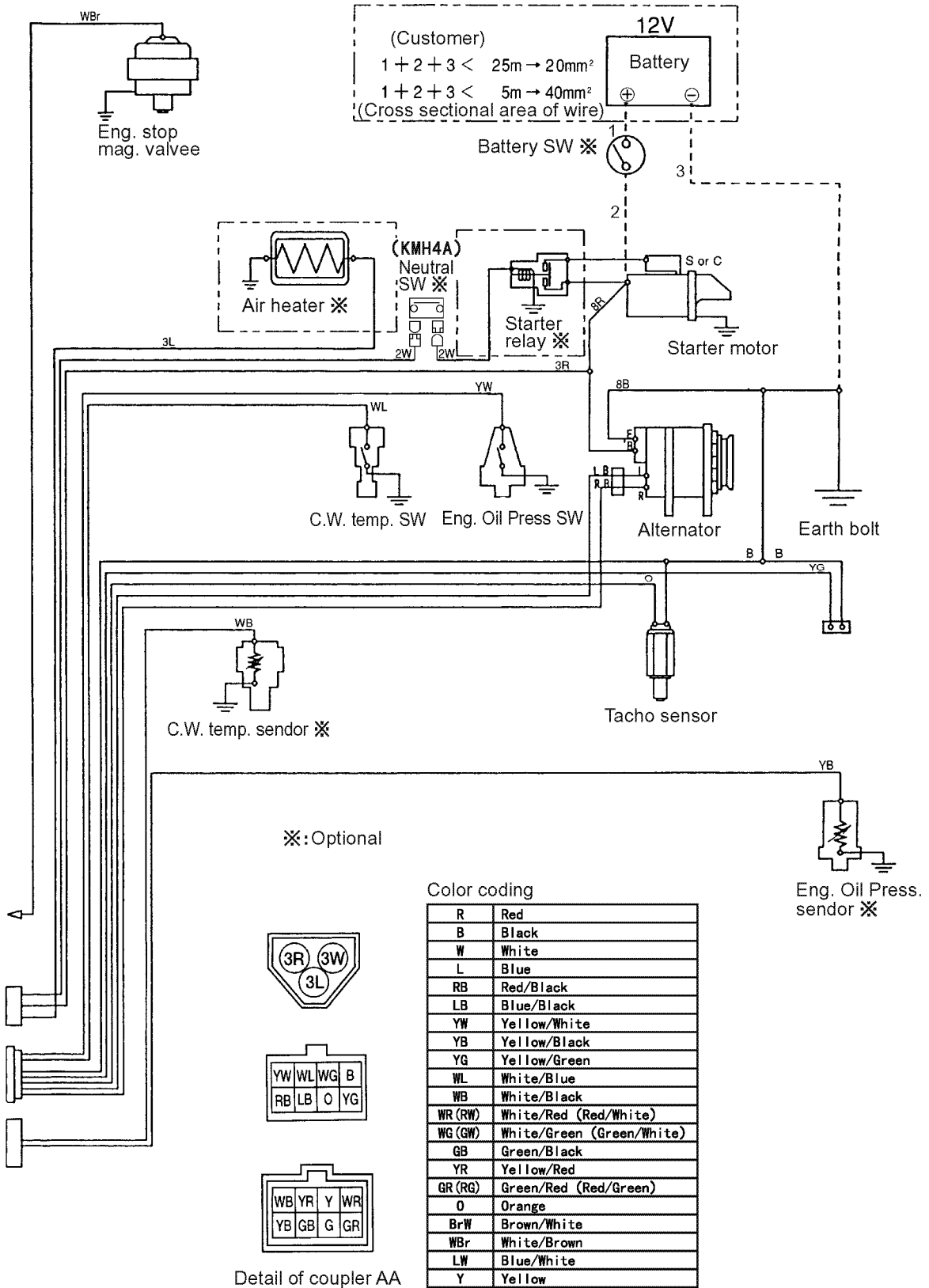

### 7.1.3 New B type Instrument Panel (Optional) 1/2 (Panel side)

Color coding

R	Red
B	Black
W	White
L	Blue
RB	Red/Black
LB	Blue/Black
YW	Yellow/White
YB	Yellow/Black
YG	Yellow/Green
WL	White/Blue
WB	White/Black
WR (RW)	White/Red (Red/White)
WG (GW)	White/Green (Green/White)
GB	Green/Black
YR	Yellow/Red
GR (RG)	Green/Red (Red/Green)
O	Orange
BrW	Brown/White
WBr	White/Brown
LW	Blue/White
Y	Yellow

Starter switch

	30	AC	17	G1	G2	P1	P2	AR
GLOW	○			○		○	○	○
OFF	○					○	○	○
ON	○	○				○	○	○
START	○	○	○	○		○	○	○

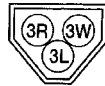

Detail of coupler CC

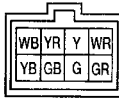
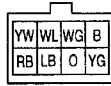

Detail of coupler AA

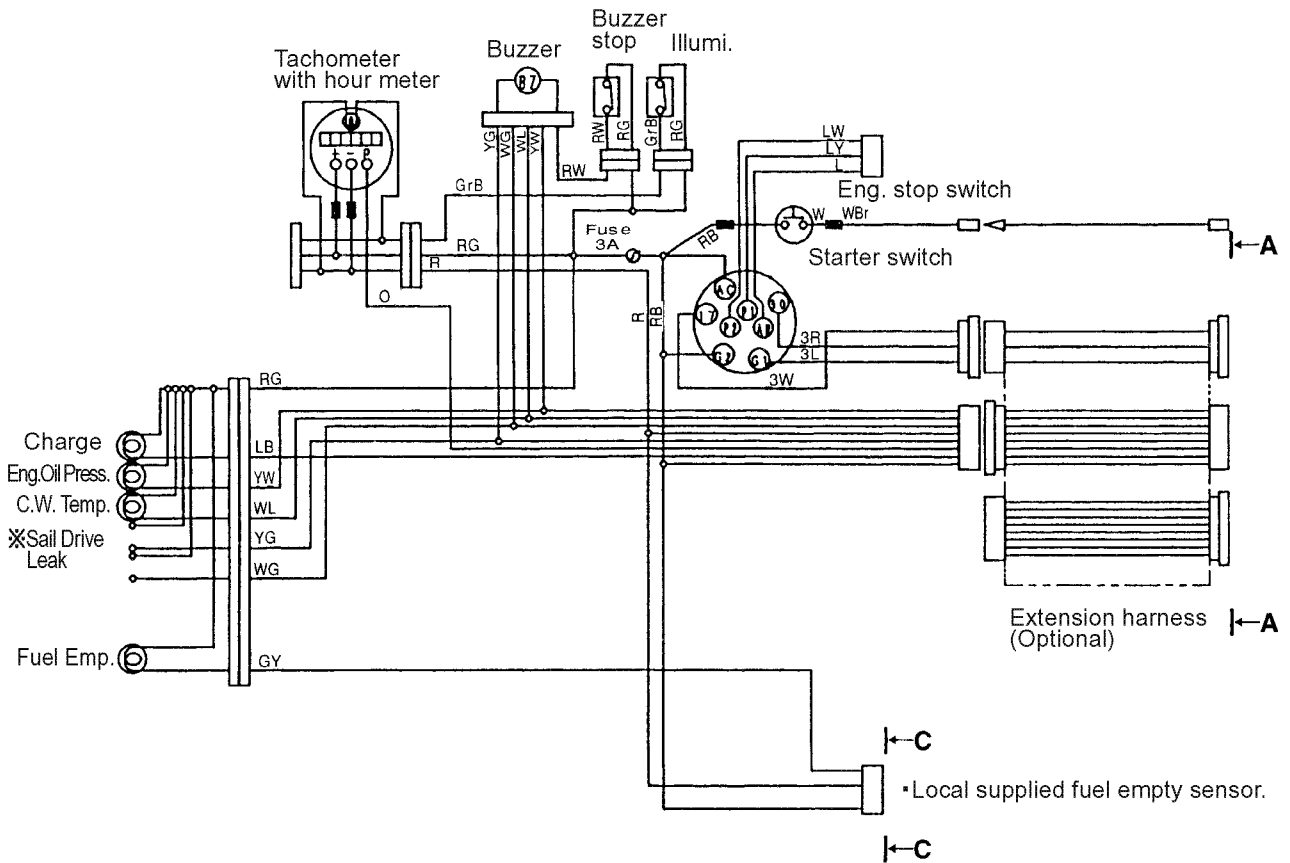

### 2/2 (Engine side)

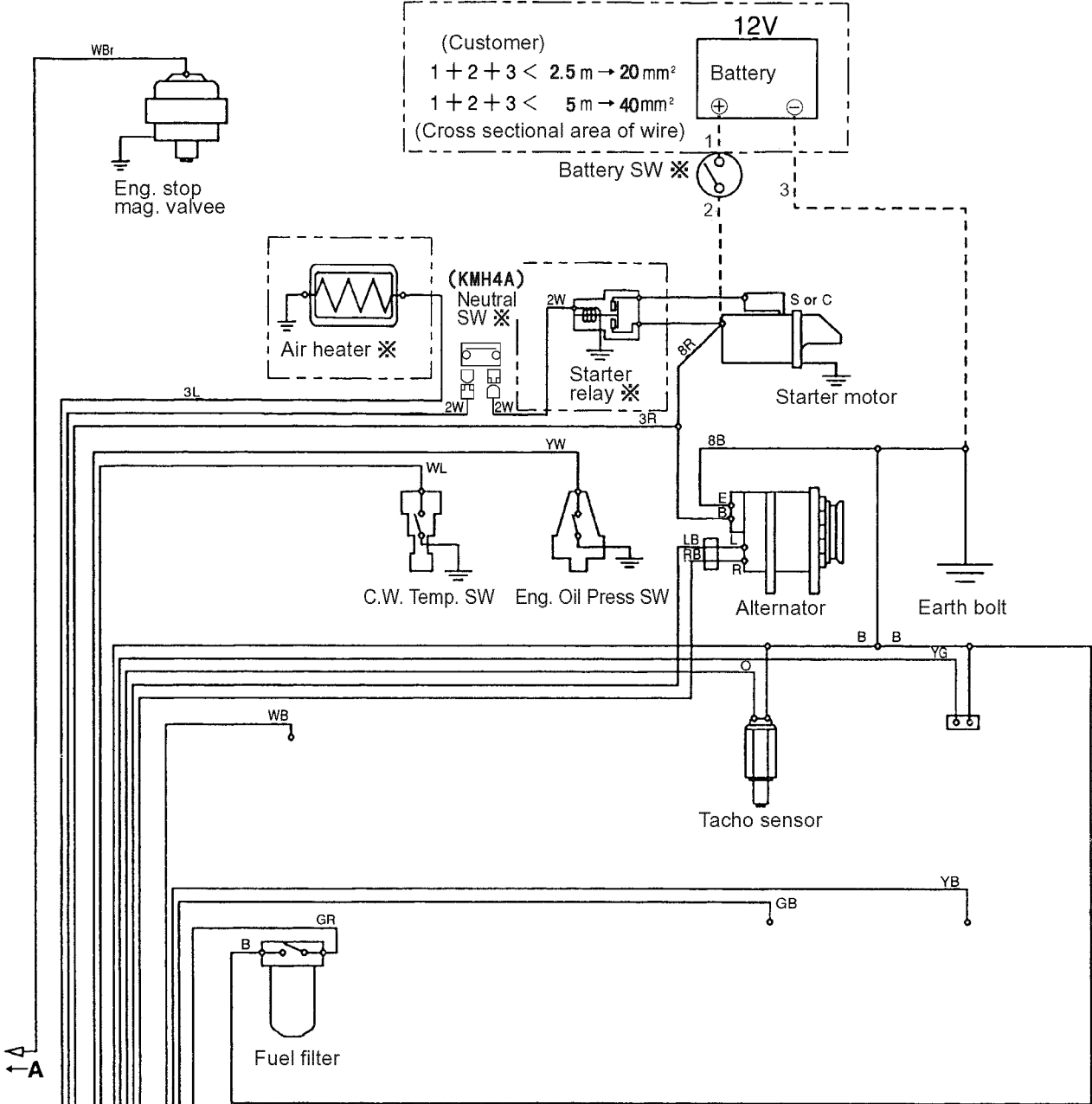

※: Optional

• Local supplied sail drive leak sensor.

### 7.1.4 New C type / New C type × New B type(No.2 station) Instrument Panel (Optional) 1/2 (Panel side)

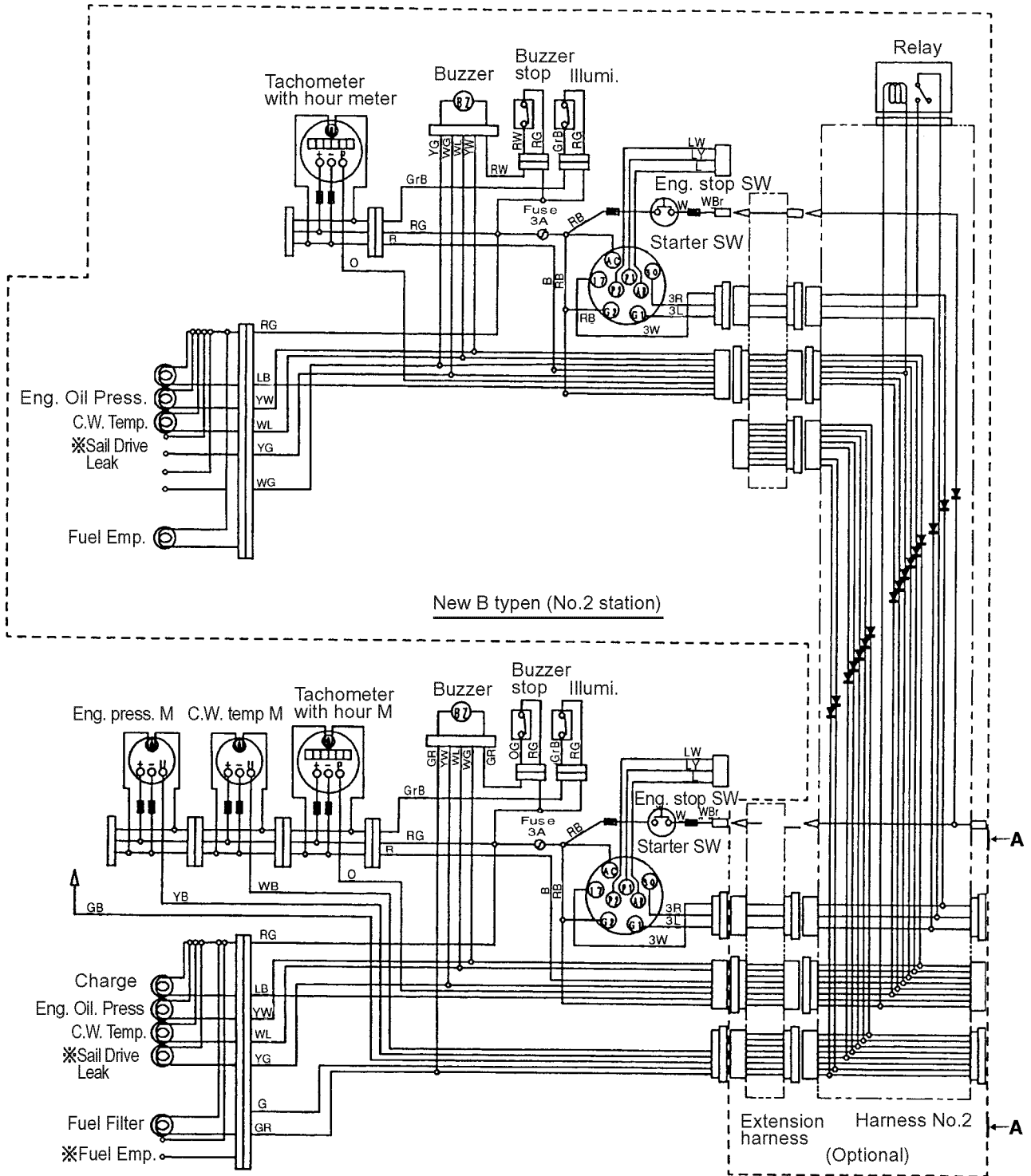

\*Local supplied fuel empty sensor.

2/2 (Engine side)

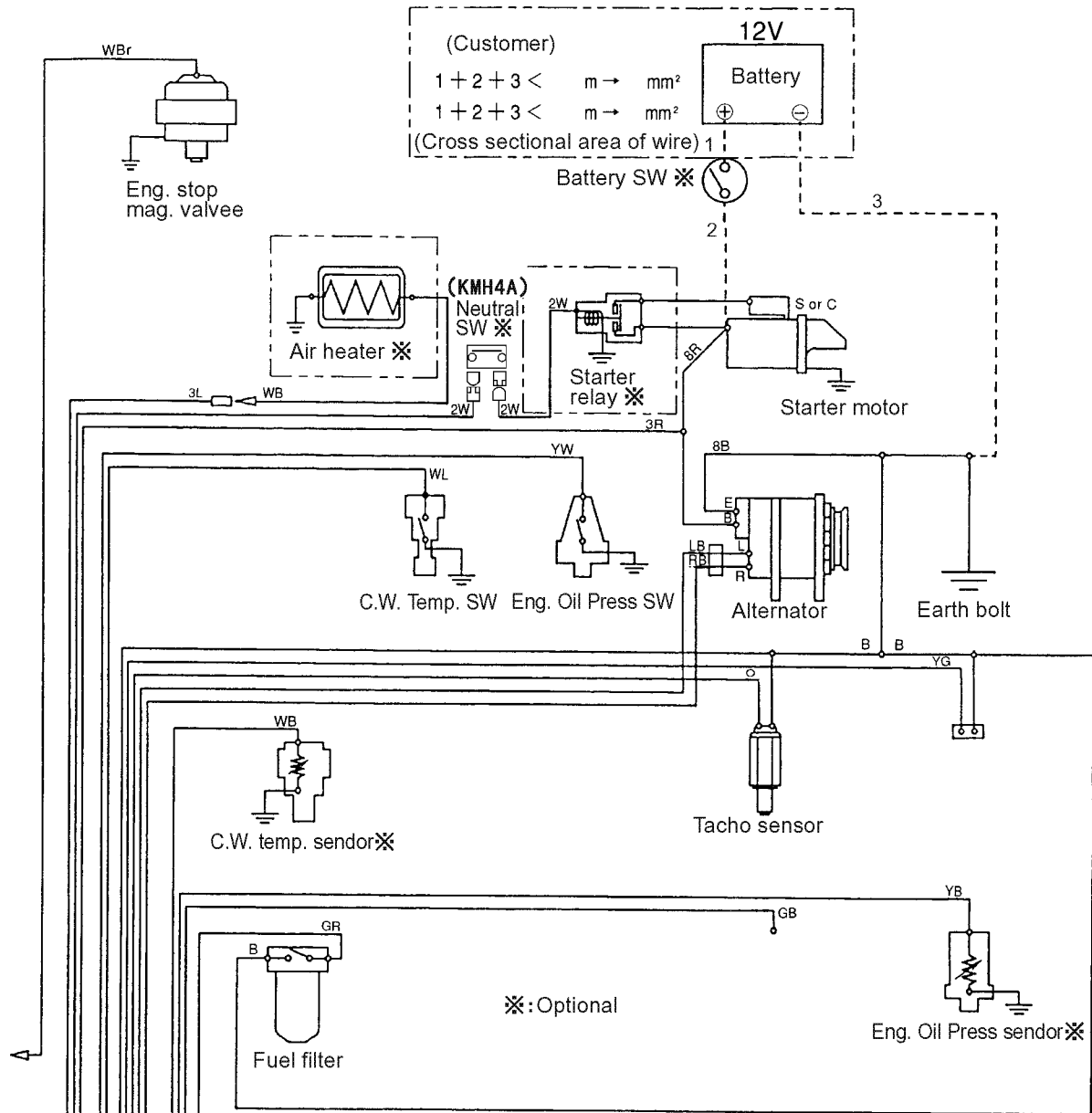

※: Optional

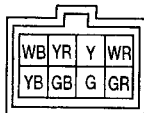
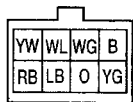
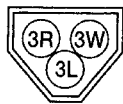

Detail of coupler AA

Color coding

R	Red
B	Black
W	White
L	Blue
LB	Red/Black
LB	Blue/Black
YW	Yellow/White
YB	Yellow/Black
YG	Yellow/Green
WL	White/Blue
WB	White/Black
WR (RW)	White/Red (Red/White)
WG (GW)	White/Green (Green/White)
GB	Green/Black
YR	Yellow/Red
GR (RG)	Green/Red (Red/Green)
O	Orange
BrW	Brown/White
WBr	White/Brown
LW	Blue/White
Y	Yellow

Starter switch

	30	AC	17	G1	G2	P1	P2	AR
GLOW	○	—	○			○	—	○
OFF	○					○	—	○
ON	○	—	○			○	—	○
START	○	—	○	—	○	○	—	○

• Local supplied sail drive leak sensor.

Operation Manual	Models : Marine Engine <b>4JH3-TE/-TCE/-HTE/-DTE</b>	Code No. 49961-202851
------------------	---	--------------------------

ALL Right Reserved, Copyright © YANMAR DIESEL ENGINE CO.,LTD. 1998





# **YANMAR DIESEL ENGINE CO.,LTD.**

## **OVERSEAS OPERATIONS DIVISION**

1-32, CHAYAMACHI, KITA-KU, OSAKA 530-8311, JAPAN

TEL : 81-6-6376-6411

FAX : 81-6-6377-1242

## **YANMAR DIESEL AMERICA CORP.**

951 CORPORATE GROVE DRIVE, BUFFALO GROVE, IL 60089-4508, U.S.A

TEL : 1-847-541-1900

FAX : 1-847-541-2161

## **YANMAR EUROPE B.V.**

BRUGPLEIN 11, 1332 BS ALMERE-DE VAART, THE NETHERLANDS P.O.BOX 30112, 1303

TEL : 31-36-5493200

FAX : 31-36-5493209

## **YANMAR ASIA (SINGAPORE) CORPORATION PTE LTD.**

4 TUAS LANE. SHINGAPORE 638613

TEL : 65-861-3855

FAX : 65-862-5195

User's record

Date of purchase
Place of purchase (Name of dealer)